

Bombas y Motores de engranajes

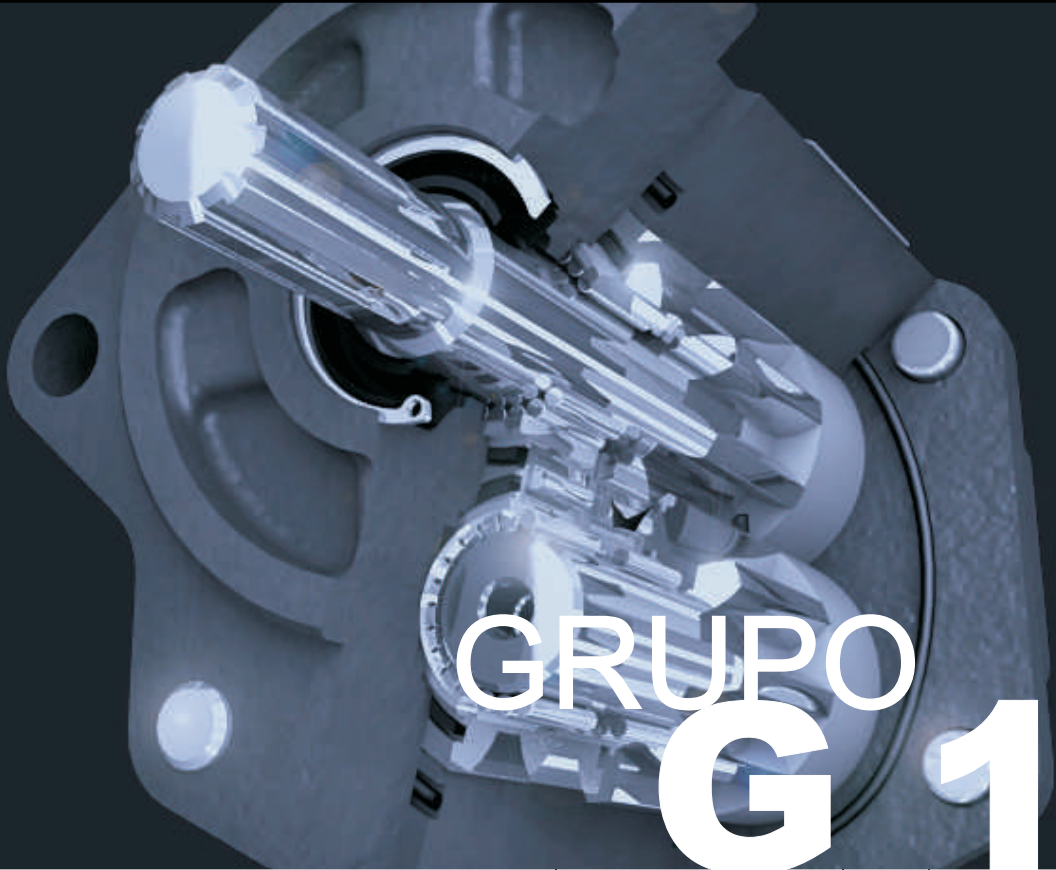

Caudales de 8 a 60 lts/min a 2000 rpm

Presiones hasta 200 bar  
Motores hasta 18 hp



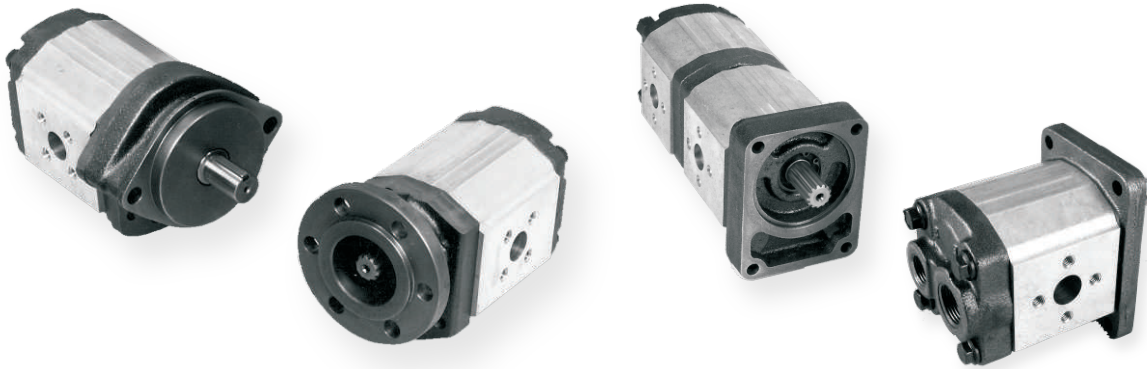

Se trata de un conjunto de bombas y motores de engranajes, que abarca caudales de 8 / 16 / 24 / 32 / 40 / 45 / 50 / 60 lts/min a 2000 rpm y presiones hasta 200 bar.

Las tomas de fijación y tapas posteriores están construidas en fundición **de hierro**, mientras que los cuerpos son de **aleación de aluminio**.

Los engranajes, apoyan sobre **casquillos de fricción o rodamientos de rodillos** y están compensados hidráulicamente con **bujes anti-fricción de aleación de aluminio**.

Para la dimensiones de montaje se utilizan como guía de referencia las **normativas SAE y DIN**.

Es posible armar **unidades múltiples: G1 / G1**. Esto permite seleccionar diversas combinaciones de caudales, como así también, disponer de todas las versiones de **tapas posteriores**.

Ademas el conjunto **G1** puede combinarse como bomba trasera de un conjunto **P250, P5, G2/3, G15**.

Para la correcta elección de una bomba se debe considerar la presión de trabajo, necesidad de caudal real, dimensiones de montaje, potencia absorbida, características del actuador, espacio físico, etc.

Las aplicaciones mas importantes del **grupo G1** son:

Tractores, cosechadoras, fumigadoras, sembradoras, camiones volcadores, centrales hidráulicas, prensas hidráulicas, maquinas industriales, autoelevadores, etc.

## Recomendaciones:

- Utilizar aceite hidráulico específico.
- Utilizar filtros, tanto de succión como de retorno, apropiado y debidamente dimensionados.
- Asegúrese que el circuito tenga la velocidad de circulación del fluido correcta, evitando cavitación en la succión.
- Evitar sobrepresiones (picos de presión) que superen los límites permitidos recomendados.
- Asesórese y consulte, a nuestro Departamento de Ingeniería cuando lo considere necesario.





## BOMBA GRUPO G1 CON CASQUILLO DE FRICCIÓN

GRUPO  
**G1**

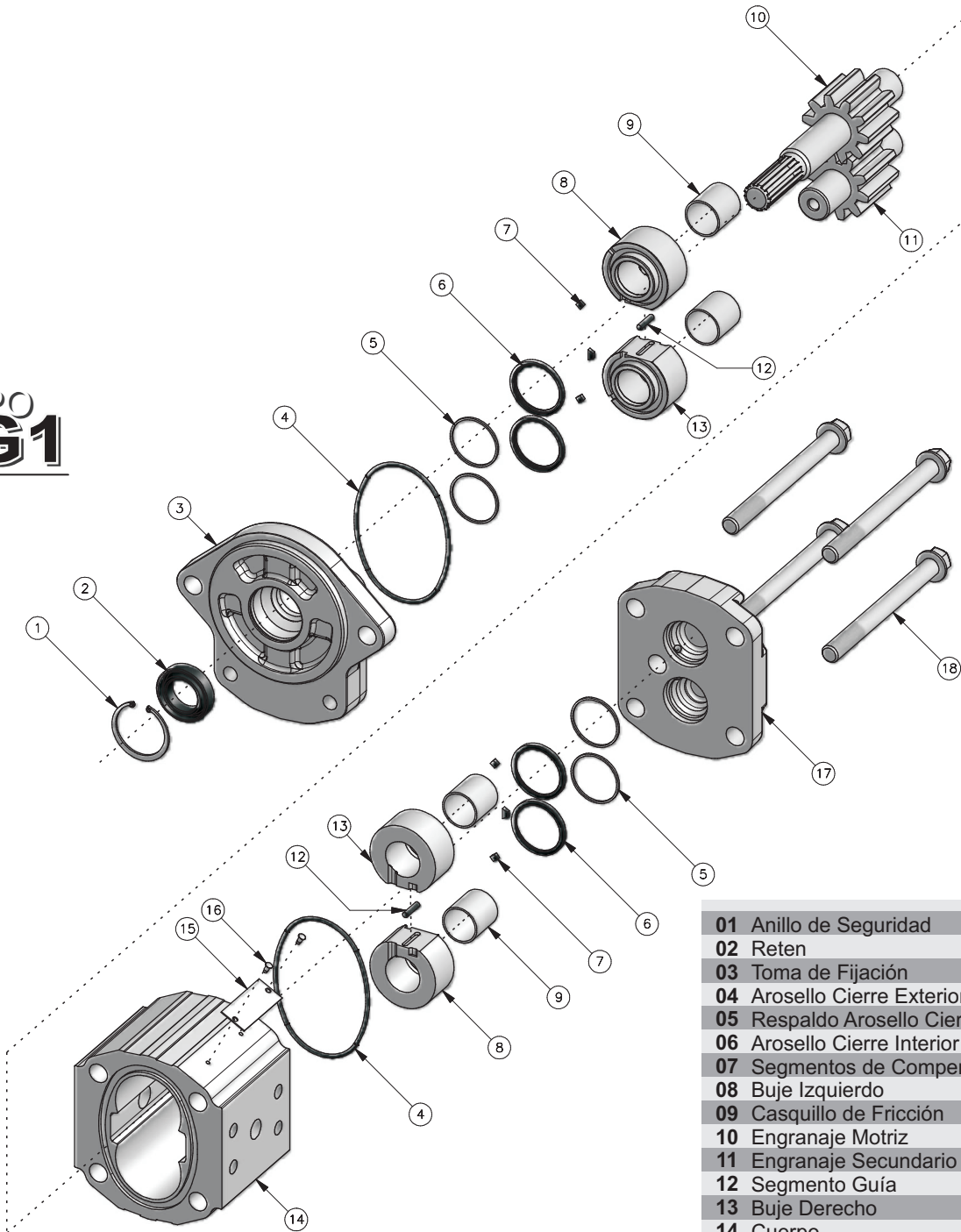

- |    |                                   |
|----|-----------------------------------|
| 01 | Anillo de Seguridad               |
| 02 | Reten                             |
| 03 | Toma de Fijación                  |
| 04 | Arosello Cierre Exterior          |
| 05 | Respaldo Arosello Cierre Interior |
| 06 | Arosello Cierre Interior          |
| 07 | Segmentos de Compensación         |
| 08 | Buje Izquierdo                    |
| 09 | Casquillo de Fricción             |
| 10 | Engranaje Motriz                  |
| 11 | Engranaje Secundario              |
| 12 | Segmento Guía                     |
| 13 | Buje Derecho                      |
| 14 | Cuerpo                            |
| 15 | Placa Identificación              |
| 16 | Remache                           |
| 17 | Tapa Posterior                    |
| 18 | Tornillo Cabeza Hexagonal         |

LA EMPRESA SE RESERVA EL DERECHO DE REALIZAR MODIFICACIONES SIN PREVIO AVISO



## BOMBA GRUPO G1 CON RODAMIENTO DE RODILLOS

GRUPO  
**G1**

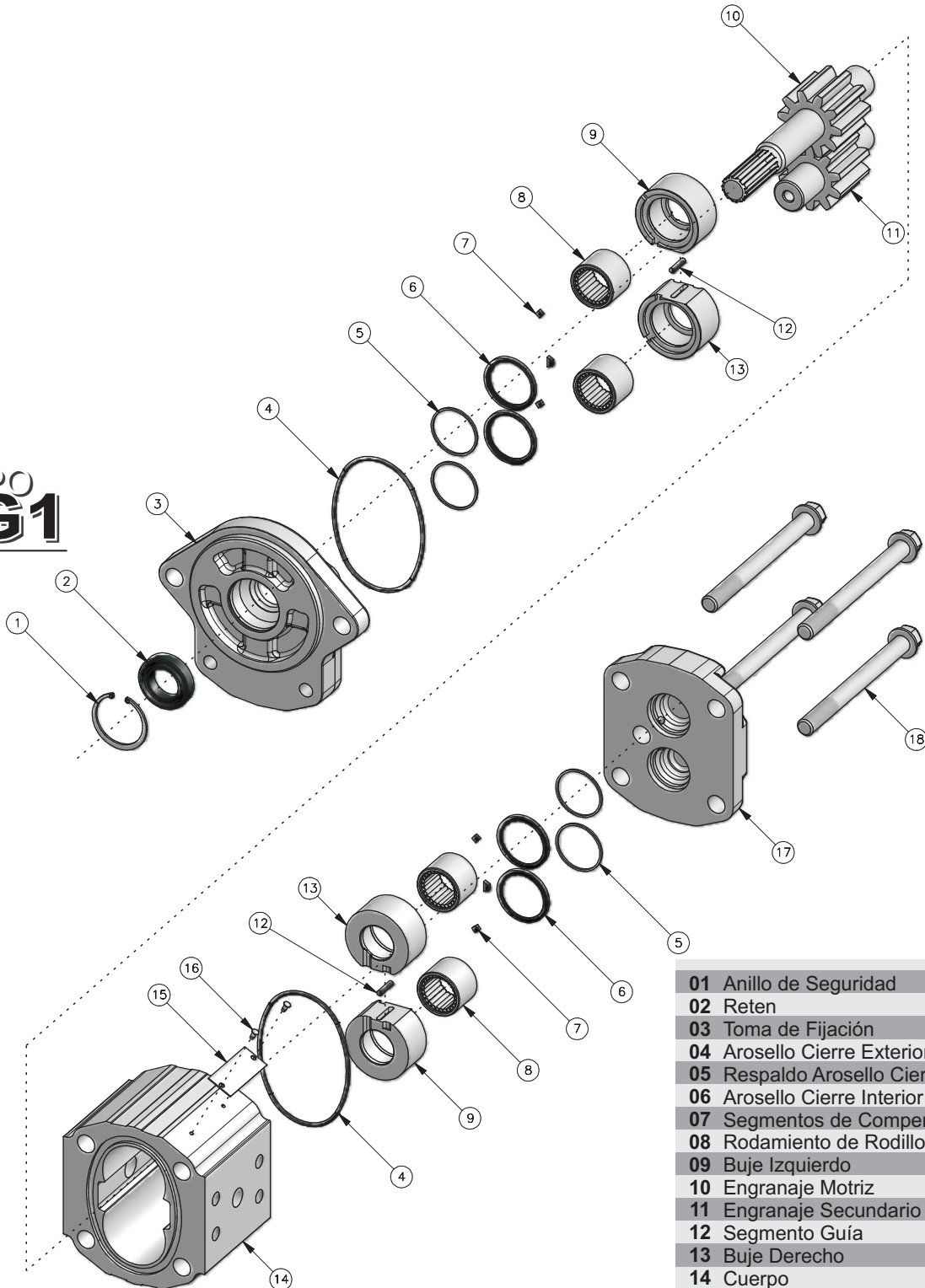

- |    |                                   |
|----|-----------------------------------|
| 01 | Anillo de Seguridad               |
| 02 | Reten                             |
| 03 | Toma de Fijación                  |
| 04 | Arosello Cierre Exterior          |
| 05 | Respaldo Arosello Cierre Interior |
| 06 | Arosello Cierre Interior          |
| 07 | Segmentos de Compensación         |
| 08 | Rodamiento de Rodillos            |
| 09 | Buje Izquierdo                    |
| 10 | Engranaje Motriz                  |
| 11 | Engranaje Secundario              |
| 12 | Segmento Guía                     |
| 13 | Buje Derecho                      |
| 14 | Cuerpo                            |
| 15 | Placa Identificación              |
| 16 | Remache                           |
| 17 | Tapa Posterior                    |
| 18 | Tornillo Cabeza Hexagonal         |

LA EMPRESA SE RESERVA EL DERECHO DE REALIZAR MODIFICACIONES SIN PREVIO AVISO





## BOMBA G1

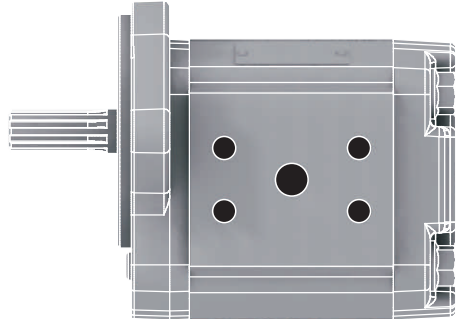

## BOMBA TANDEM G1 / G1

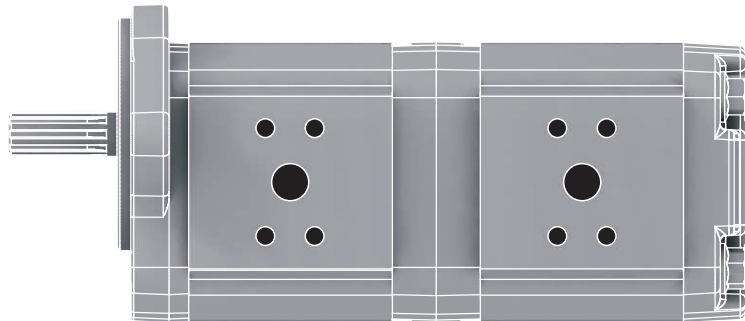

GRUPO  
**G1**

## BOMBA TANDEM G1 / G1

Para tanques independientes

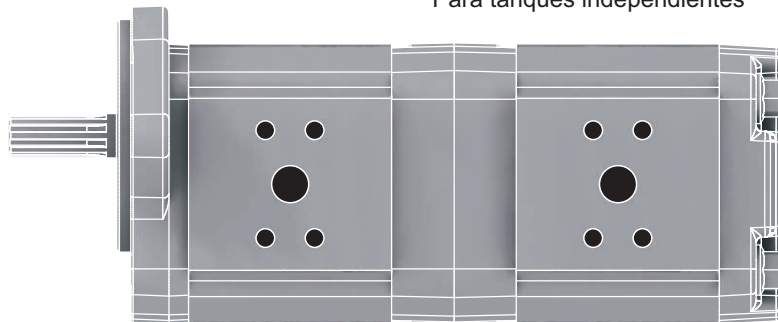

## DIVISOR DE CAUDAL ROTATIVO

Divide el caudal de una bomba en varios circuitos separados de manera estable y equilibrada, posibilitando la operación de cilindros o motores con movimientos simultáneo sincronizados. Constituye una unidad compacta y simple con secciones de engranajes acoplados entre sí. El caudal de ingreso se dividirá en proporción directa al ancho del engranaje de cada sección y el numero de secciones.

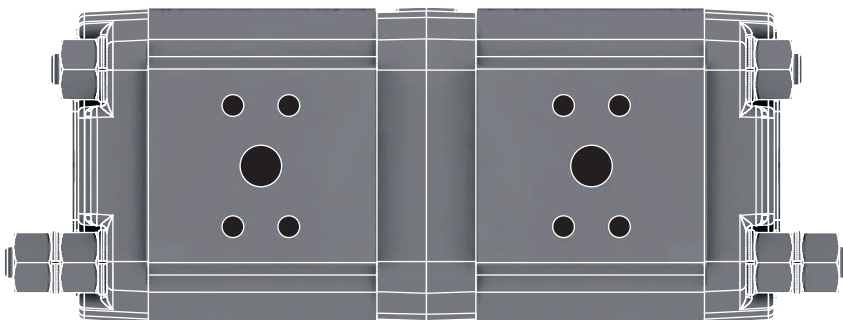



## TABLA DE VALORES

VALORACIONES		MODELOS								
		8	16	24	32	40	45	50	60	
ESPECIFICACIONES TÉCNICAS	Desplazamiento	cm <sup>3</sup> /rev	4.09	8.18	12.26	16.35	20.13	22.65	25.16	30.19
		in <sup>3</sup> /rev	0.25	0.5	0.75	1	1.23	1.38	1.53	1.84
	Caudal (a 2000 rpm)	lts/min	8	16	24	32	40	45	50	60
		gal/min	2.11	4.23	6.34	8.45	10.57	11.89	13.21	15.85
	Ancho de engranaje	mm	6.35	13	19.5	26	32	36	40	48
		inches	1/4"	33/64"	49/64"	1 1/32"	1 17/64"	1 27/64"	1 37/64"	1 57/64"
	Ancho de cuerpo	mm	46.5	53	59.5	66	72	76	80	88
		inches	1 53/64"	2 3/32"	2 11/32"	2 19/32"	2 53/64"	2 63/64"	3 5/32"	3 15/32"
	rpm	mínima	600							
		máxima	3200			3000		2800	2500	
Máxima presión de operación	bar	200			175		165	140		
	psi	2900			2537.5		2392.5	2030		
Máxima presión intermitente	bar	215		210		185	175	150		
	psi	3117.5		3045		2682.5	2537.5	2175		
Peso aproximado	kg	3.4	3.6	3.8	4	4.2	4.4	4.6	4.8	
	lb	7.5	7.94	8.38	8.82	9.26	9.7	10.14	10.58	

Temperatura durante el ensayo 50°C. Aceite hidráulico ISO 46.

GRUPO  
**G1**

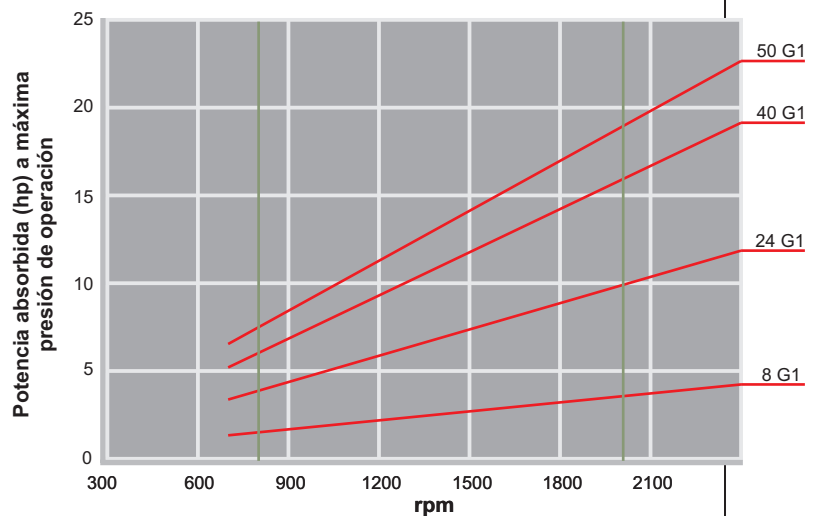
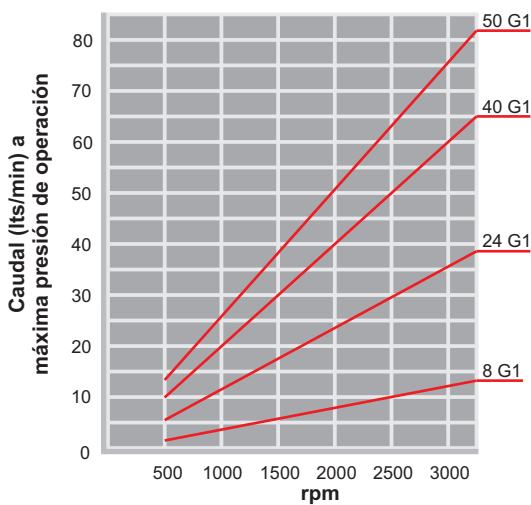

CUALQUIER OTRO REQUERIMIENTO TÉCNICO PODRÁ SER CONSULTADO A NUESTRO DEPARTAMENTO DE INGENIERÍA



## RENDIMIENTO MOTOR G1

VELOCIDAD (rpm)	MODELOS											
	16			32			45			60		
	ENT.	SAL.		ENT.	SAL.		ENT.	SAL.		ENT.	SAL.	
	CAUDAL (Alimentación)	TORQUE	POTENCIA	CAUDAL (Alimentación)	TORQUE	POTENCIA	CAUDAL (Alimentación)	TORQUE	POTENCIA	CAUDAL (Alimentación)	TORQUE	POTENCIA
	lts/min gal/min	kgm In-lb	hp kW	lts/min gal/min	kgm In-lb	hp kW	lts/min gal/min	kgm In-lb	hp kW	lts/min gal/min	kgm In-lb	hp kW
800	7.8	1.7	1.9	15.6	3.4	3.8	22.0	4.9	5.5	28.8	5.5	6.2
	2.1	145.9	1.4	4.1	299.1	2.9	5.8	425.7	4.1	7.6	481.6	4.6
1200	11.7	1.7	2.8	23.0	3.5	5.8	32.4	4.9	8.2	42.5	5.5	9.3
	3.1	145.9	2.1	6.1	302.7	4.4	8.6	425.7	6.2	11.2	481.6	7.0
1600	15.4	1.8	4.0	30.7	3.6	8.0	42.8	5.0	11.1	56.6	5.6	12.5
	4.1	155.0	3.0	8.1	310.0	6.0	11.3	430.9	8.3	15.0	487.4	9.4
2000	19.0	1.7	4.9	38.1	3.5	9.9	53.1	5.0	13.9	70.8	5.6	15.7
	5.0	145.9	3.7	10.1	302.7	7.4	14.0	430.9	10.4	18.7	487.4	11.8
2400	22.8	1.7	5.8	45.7	3.5	11.7	63.7	5.0	16.6	85.0	5.5	18.6
	6.0	145.9	4.4	12.1	302.7	8.8	16.8	430.9	12.5	22.4	481.6	13.9

Los ensayos se realizaron a una presión de operación de 165 bar  
Temperatura durante el ensayo 50°C. Aceite hidráulico ISO 46.

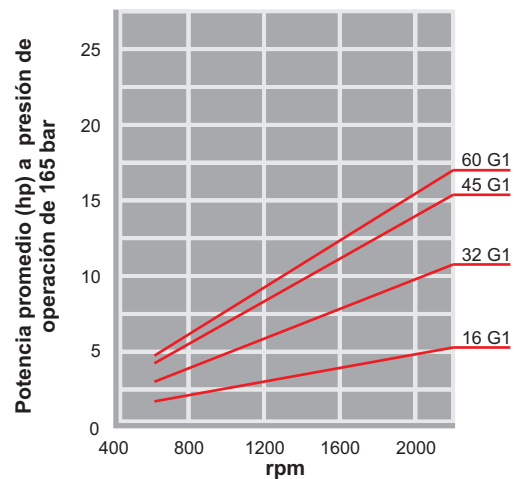
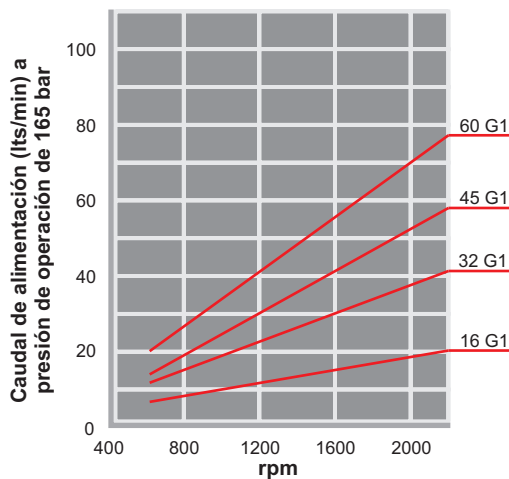

CUALQUIER OTRO REQUERIMIENTO TÉCNICO PODRÁ SER CONSULTADO A NUESTRO DEPARTAMENTO DE INGENIERÍA



## TOMA DE FIJACIÓN PL (Ø36.5)

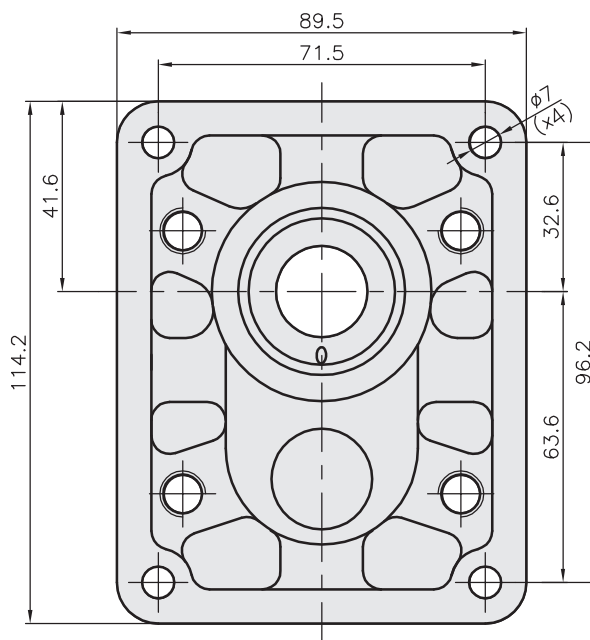
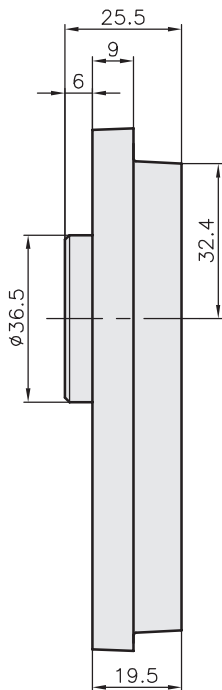

GRUPO  
**G1**

## TOMA DE FIJACIÓN DX (Ø50)

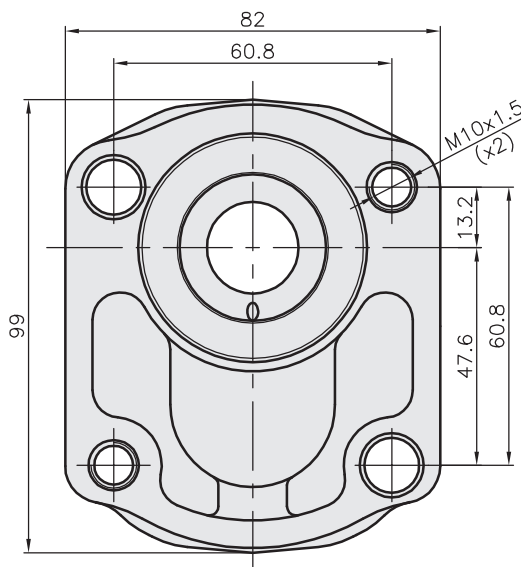
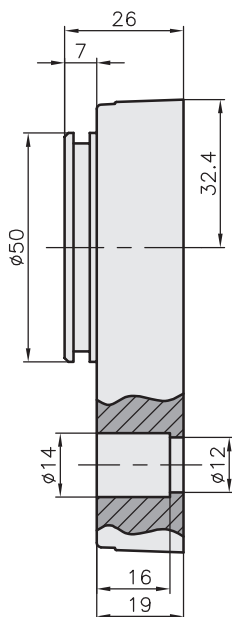





## TOMA DE FIJACIÓN DX-R (Ø50)

Con rodamiento

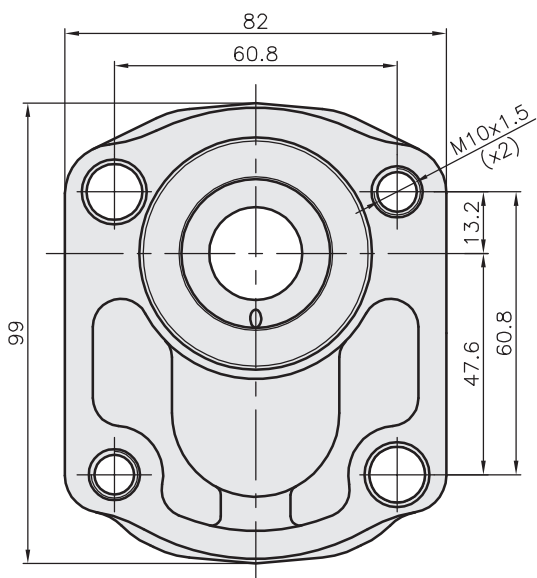
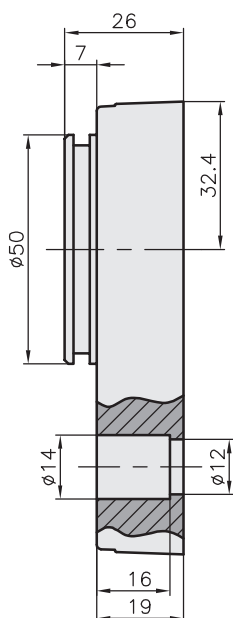

GRUPO  
**G1**

## TOMA DE FIJACIÓN F78 (Ø78)

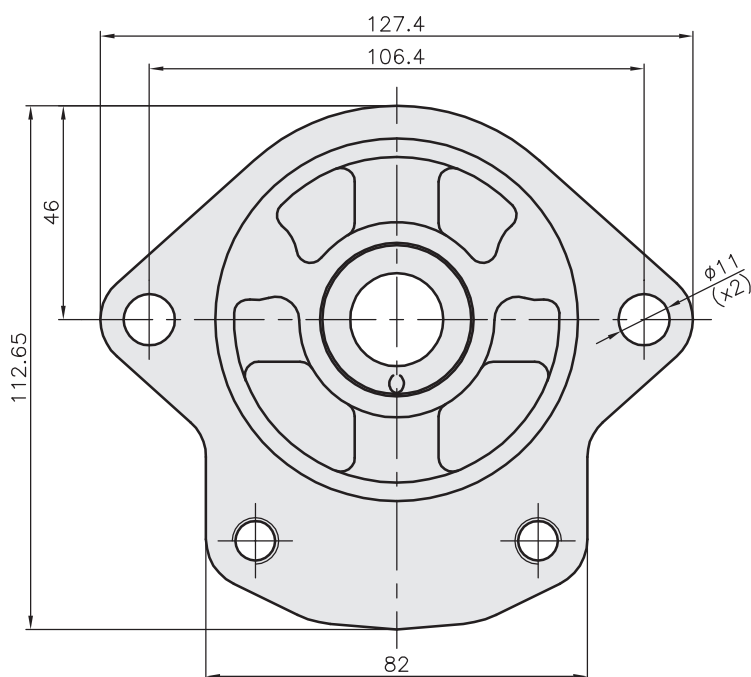
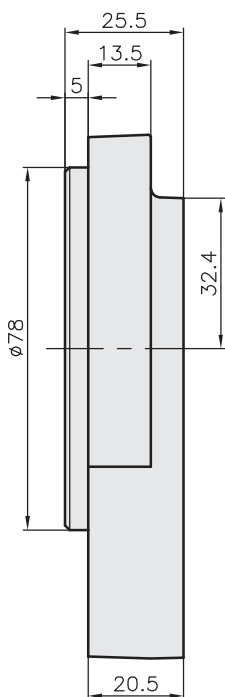



## TOMA DE FIJACIÓN F82 (Ø82.55)

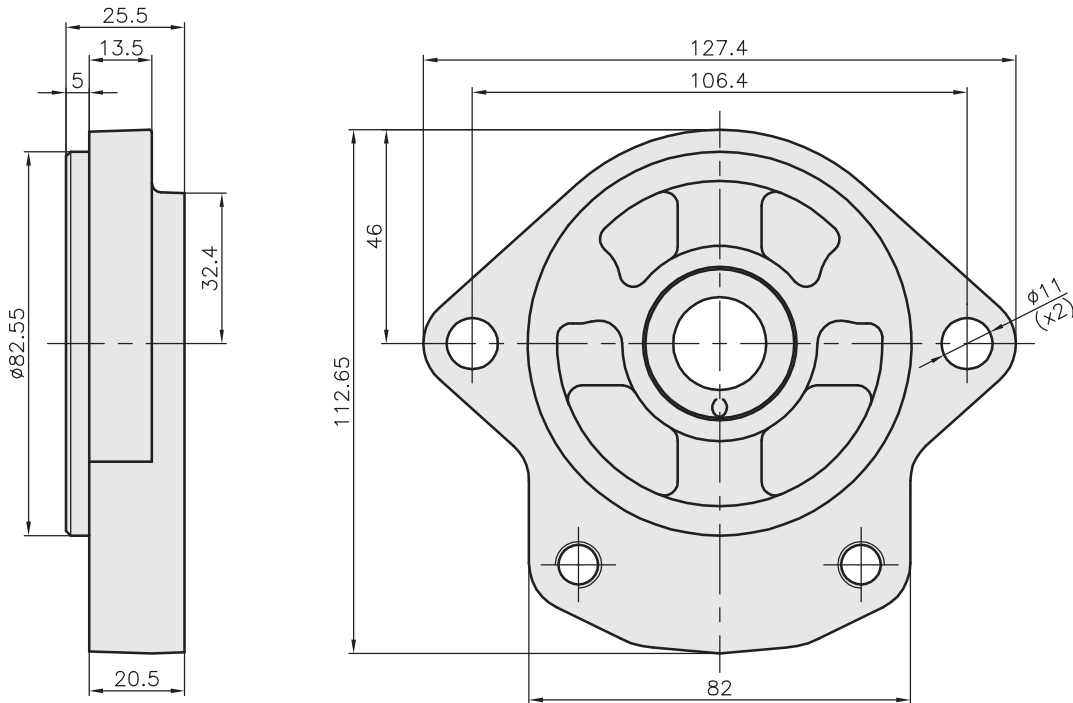

GRUPO  
**G1**

**NOTA:** PARA APLICACIÓN AGCO ALLIS CONSULTAR A NUESTRO DEPARTAMENTO DE INGENIERÍA.

## TOMA DE FIJACIÓN F88 (Ø88)

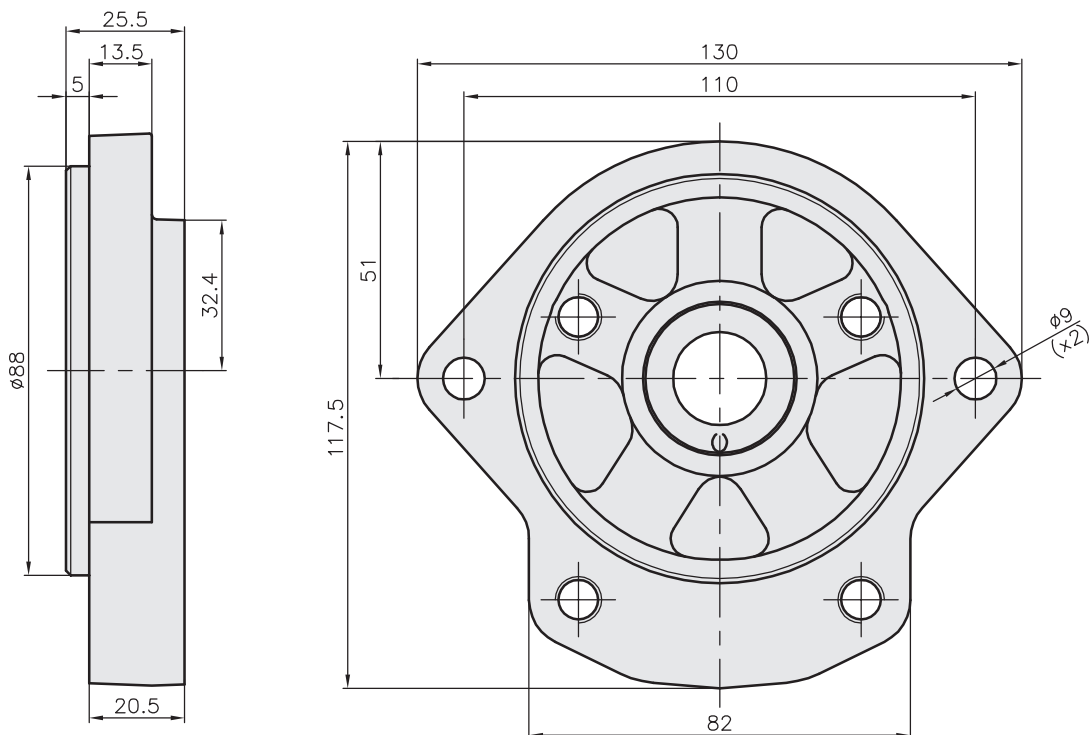



## TOMA DE FIJACIÓN MI (Ø66.67)

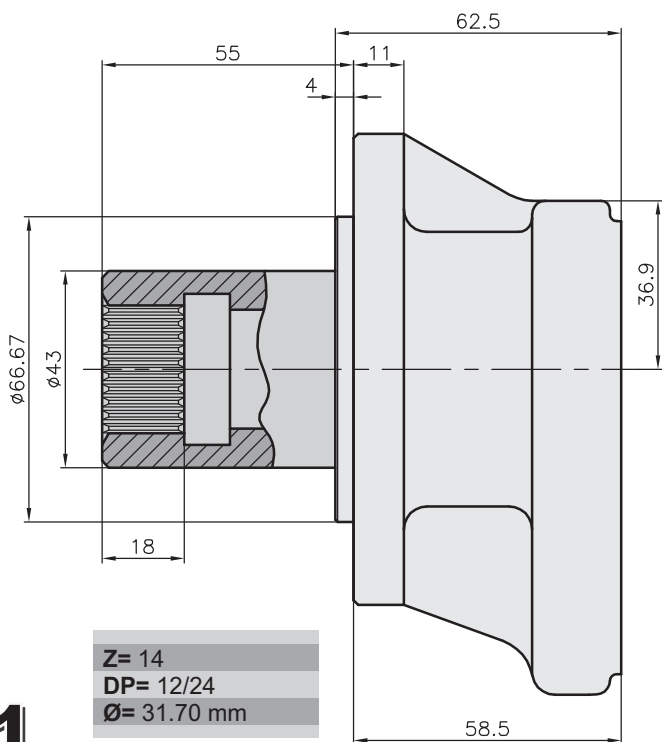

Z= 14  
DP= 12/24  
Ø= 31.70 mm

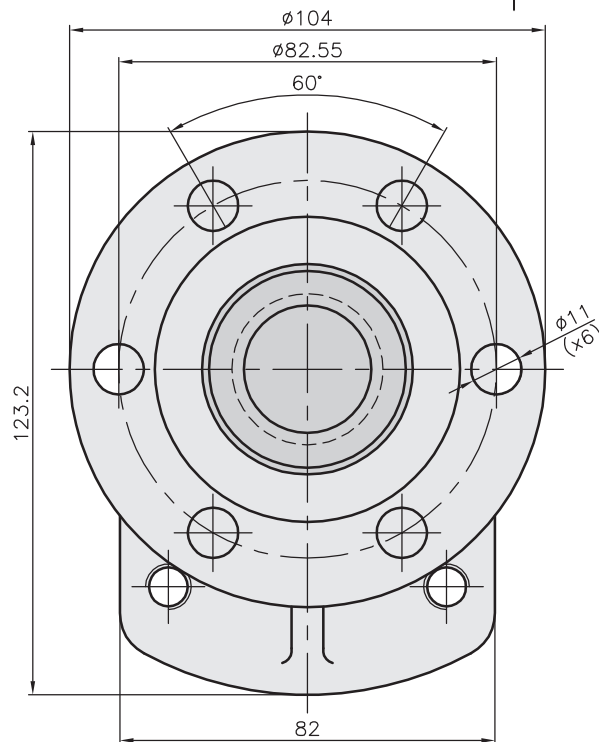

GRUPO  
**G1**

## TOMA DE FIJACIÓN TF (Ø52)

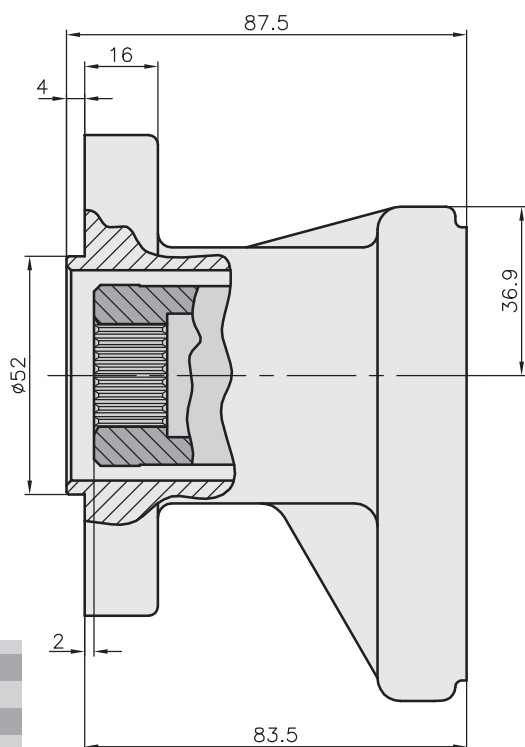

Z= 15  
DP= 16/32  
Ø= 25.4 mm

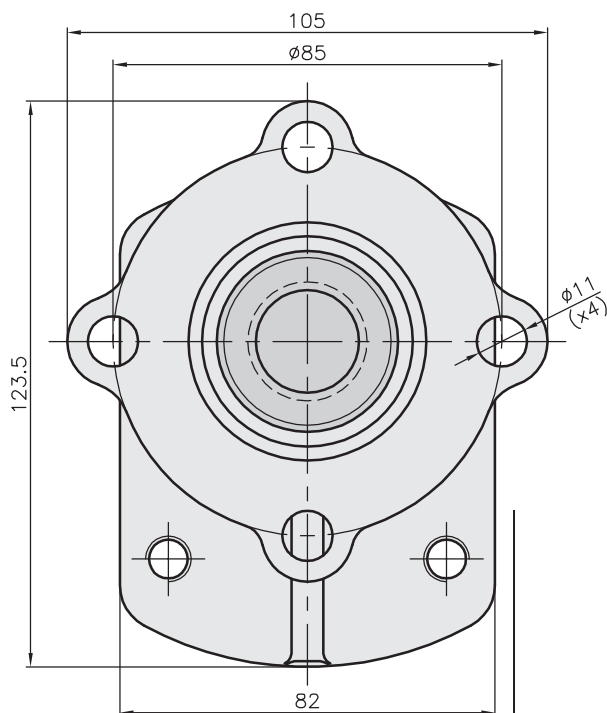



## TOMA DE FIJACIÓN DSR (Ø80)

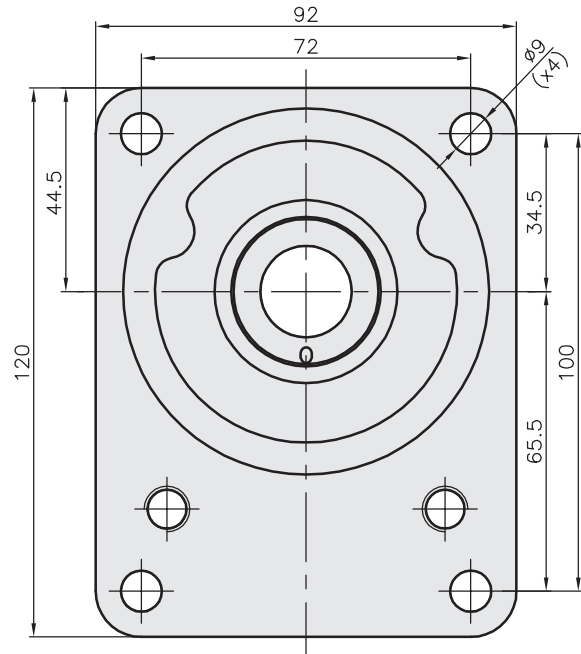
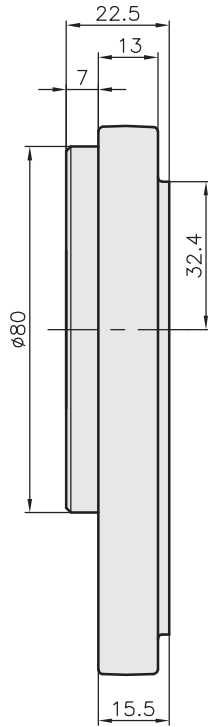

GRUPO  
**G1**

## TOMA DE FIJACIÓN F88 SEMBRADORA BERTINI (Ø88)

Aplicable a motores de engranajes de 16, 24 y 32 lts/min.

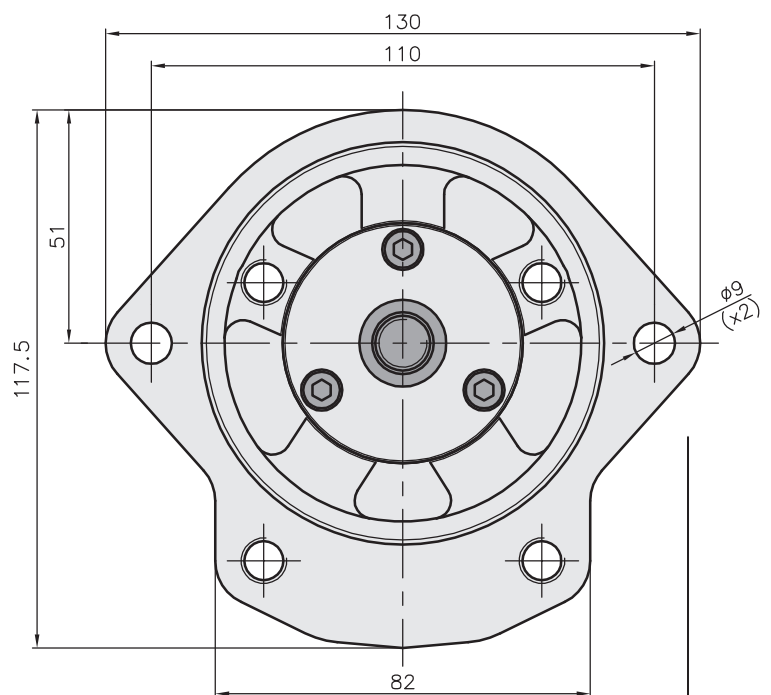
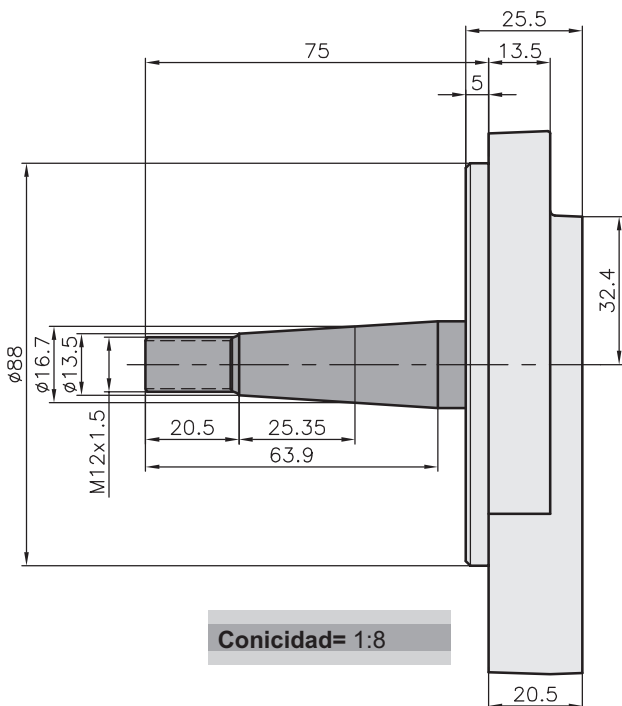





## TOMA DE FIJACIÓN GM (Ø82.55)

Con rodamiento

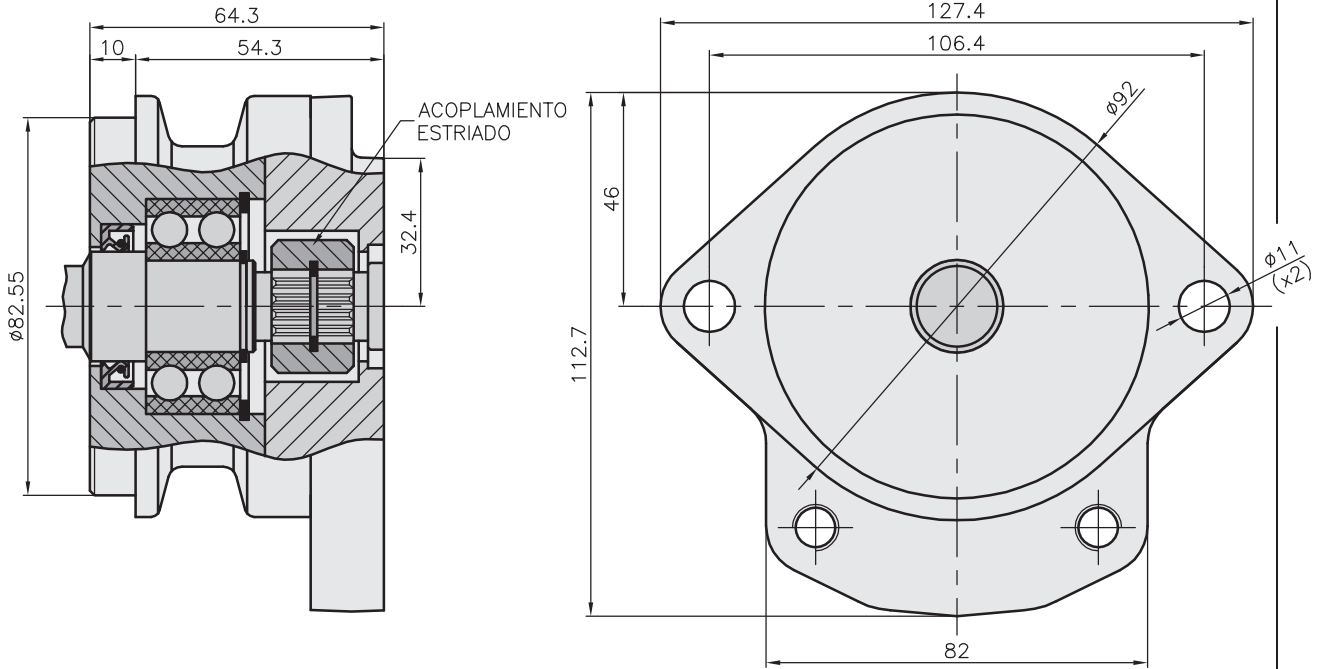

GRUPO  
**G1**

### EJES PARA APLICACIÓN EN TOMA "GM"

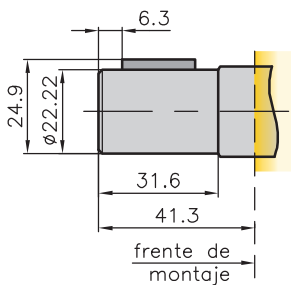

**Ø= 22.22 (7/8")**  
Chav. Cuadrada  
1/4" x 1/4" x 1"

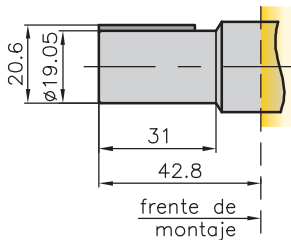

**Ø= 19.05 (3/4")**  
Chav. Rectangular  
3/16" x 5/32" x 1"

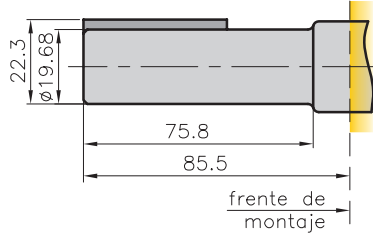

**Ø= 19.68**  
Chav. Rectangular  
4.9 x 5.5 x 53

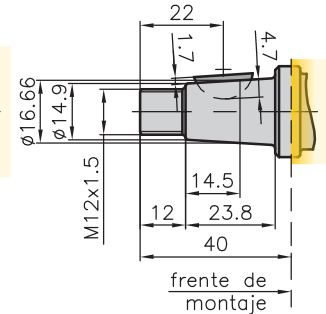

**Conicidad= 1:8**  
Chav. Media Luna  
Ø3/4" x 5/32"

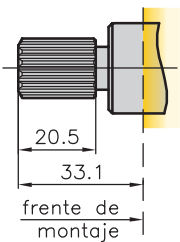

**Z= 9 Estrías**  
D/P= 16/32  
Ø15.80

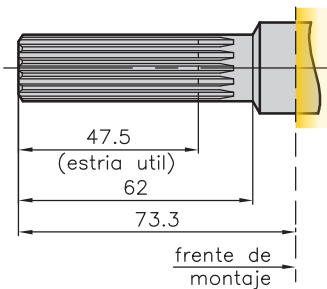

**Z= 10 Estrías**  
D/P= 16/32  
Ø17.40

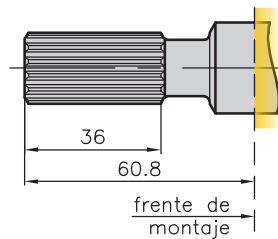

**Z= 11 Estrías**  
D/P= 16/32  
Ø19.05 (3/4")

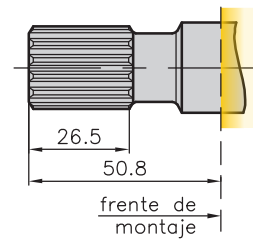

**Z= 13 Estrías**  
D/P= 16/32  
Ø22.22 (7/8")





## TOMA DE FIJACIÓN VALMET - Motor MWM (Ø45)

Aplicable a bombas tandem 45/32 lts/min.

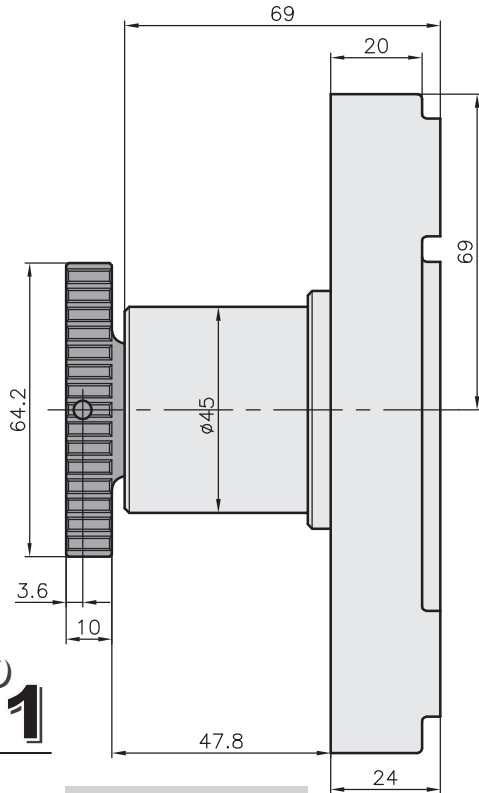

GRUPO  
**G1**

**Z= 30**  
**Modulo= 2**  
**Ø64.2**

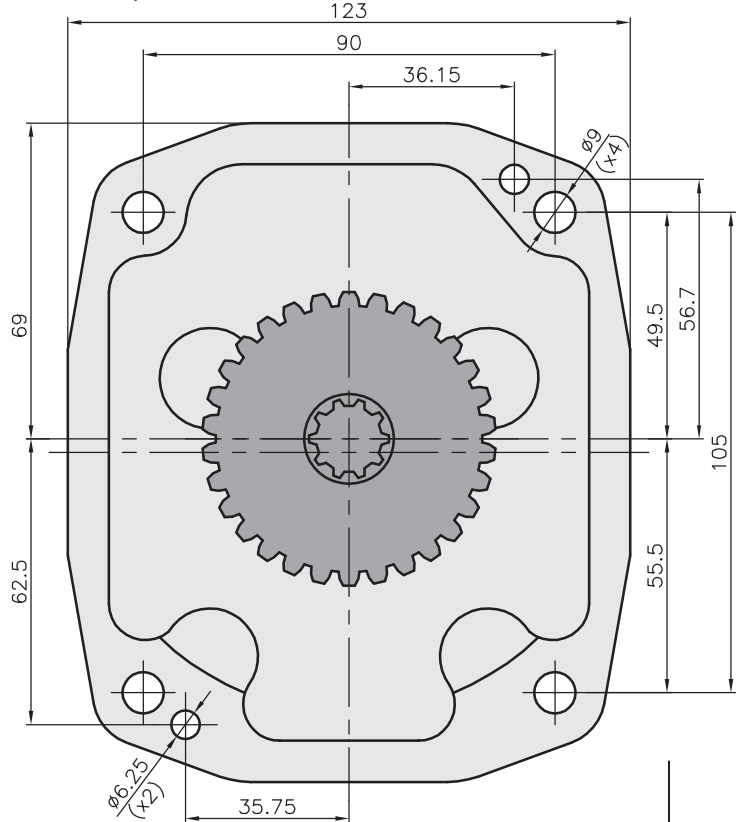

## TOMA DE FIJACIÓN VALMET - Motor VALMET (Ø75)

Aplicable a bombas tandem 45/32 lts/min.

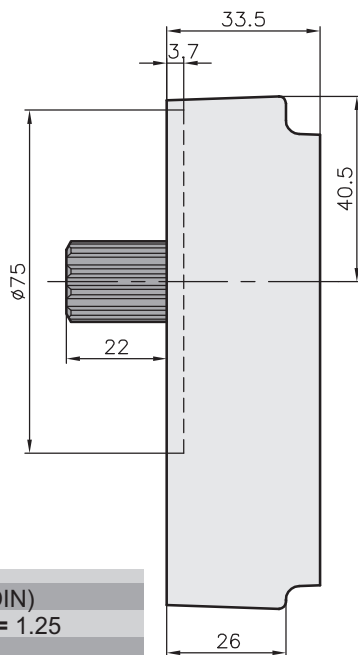

**Z= 13 (DIN)**  
**Modulo= 1.25**  
**Ø17.7**

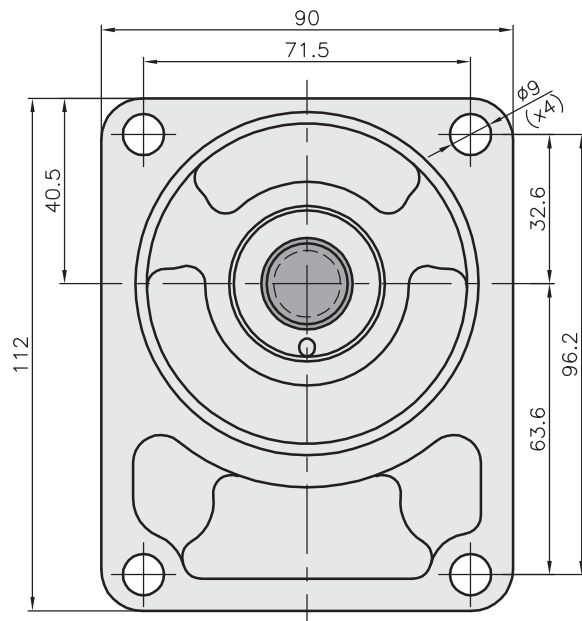



## TOMA DE FIJACIÓN VALMET - Motor CUMMINS (Ø101.6)

Aplicable a bombas tandem 45/24 lts.

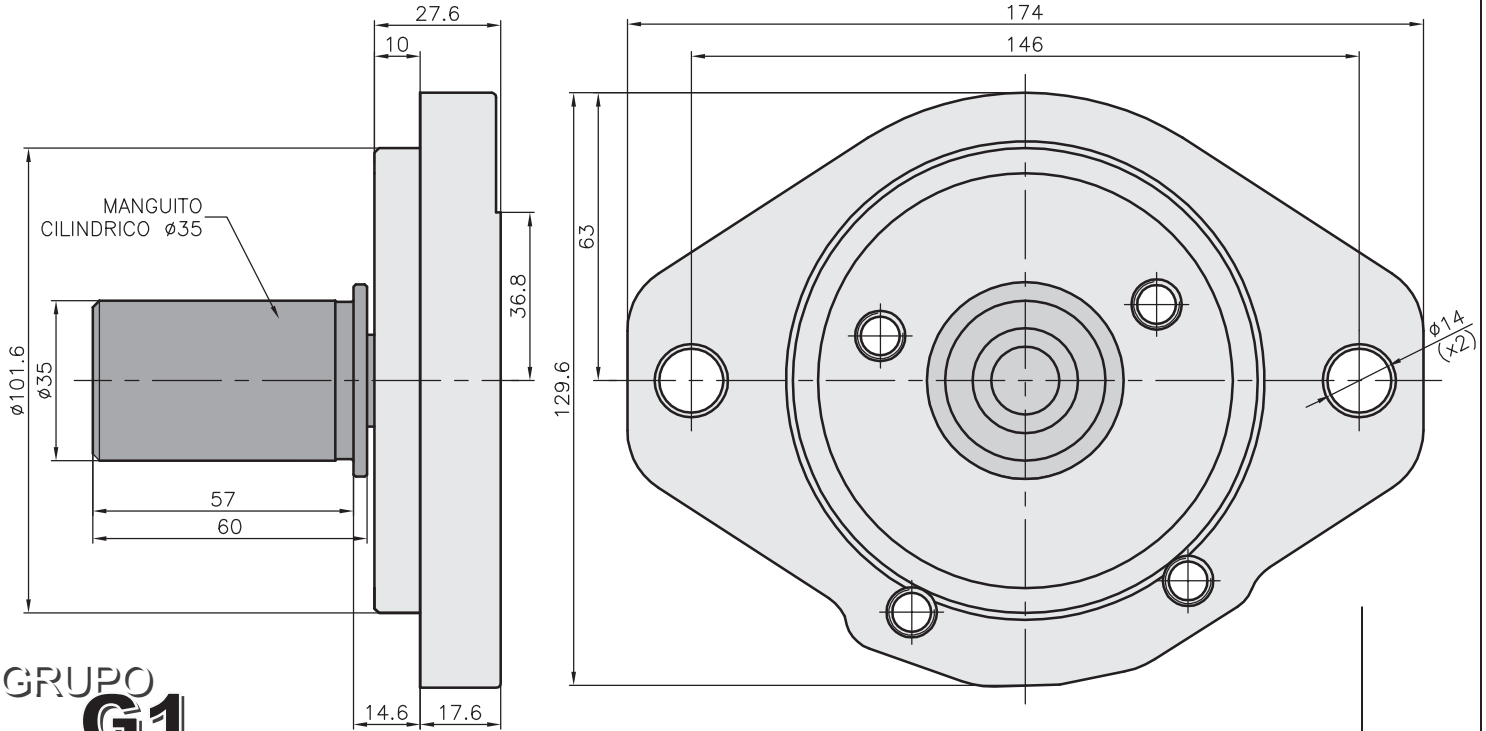

GRUPO  
**G1**

## TOMA DE FIJACIÓN 12MF (Ø66.67)

Utilizada en tractores MASSEY FERGUSON MF 1065 / 1075 / 1078 / 1088 / 1175 / 1185

Aplicable a bombas de 12, 16 y 24 lts/min.

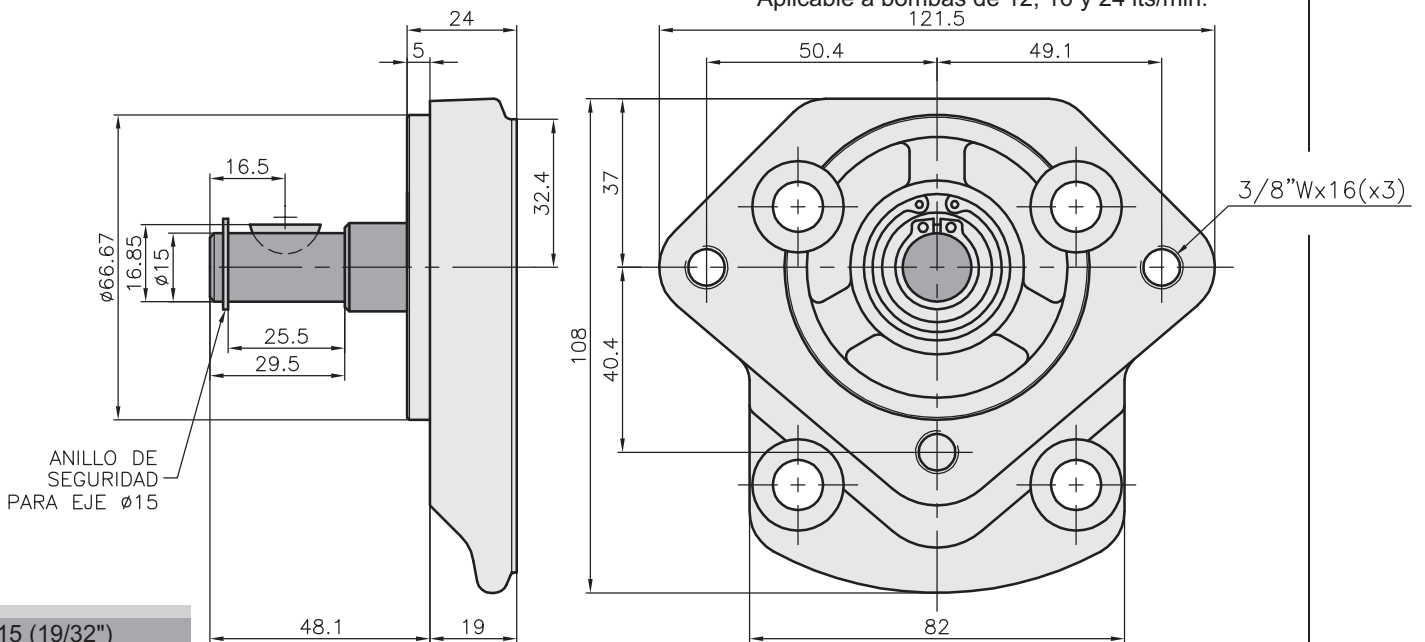

Ø= 15 (19/32")  
Chav. Media Luna  
Ø5/8" x 1/8"



## TOMA DE FIJACIÓN 24MF/1 (Ø88)

Utilizada en tractores MASSEY FERGUSON MF 1095 / 1098 / 1195

Aplicable a bombas de 24 lts/min.

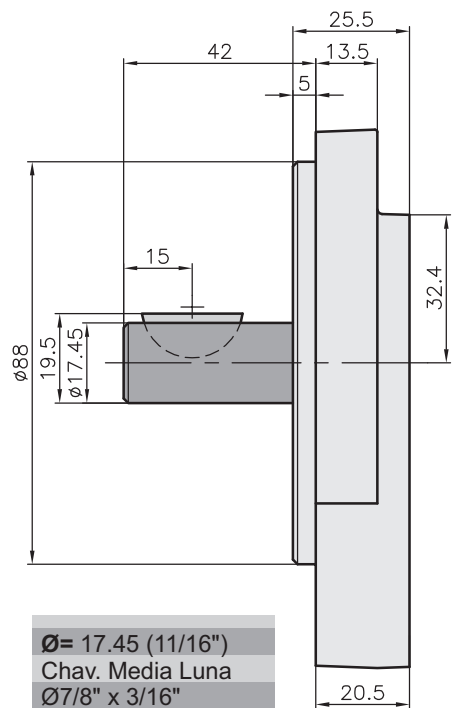

Ø = 17.45 (11/16")  
Chav. Media Luna  
Ø7/8" x 3/16"

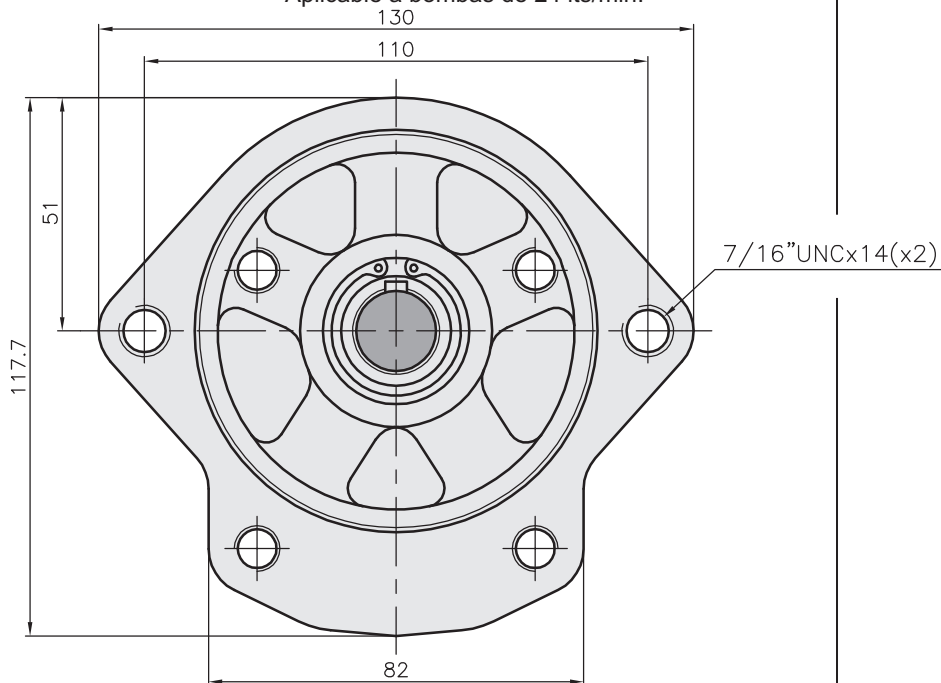

GRUPO  
**G1**

## TOMA DE FIJACIÓN 24MF/2 (Ø88)

Utilizada en tractores MASSEY FERGUSON MF 1475 / 1485

Aplicable a bombas de 24 lts/min.

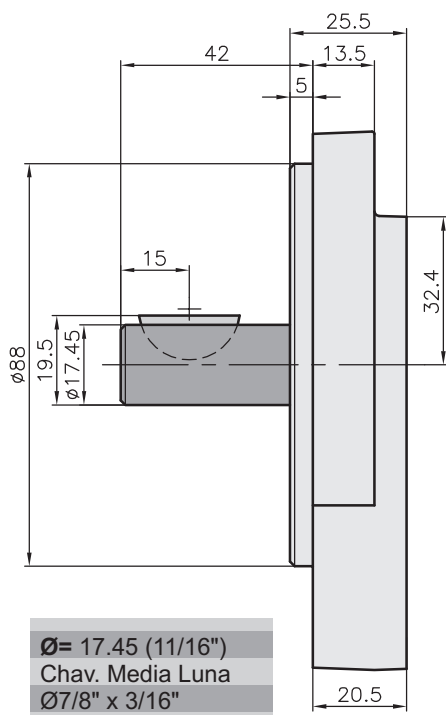

Ø = 17.45 (11/16")  
Chav. Media Luna  
Ø7/8" x 3/16"

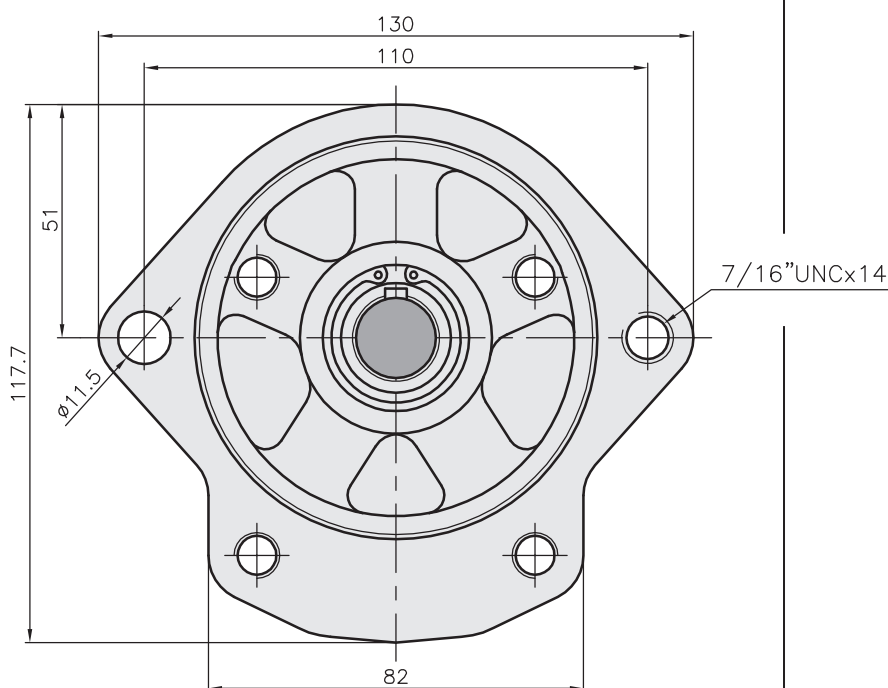



## TOMA DE FIJACIÓN ORIOL (Ø59.6)

Utilizada en motoniveladora ORIOL (dirección)  
Aplicable a bombas de 24 lts/min.

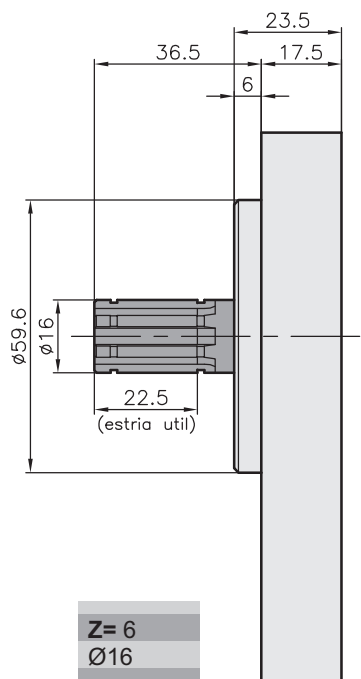

Z= 6  
Ø16

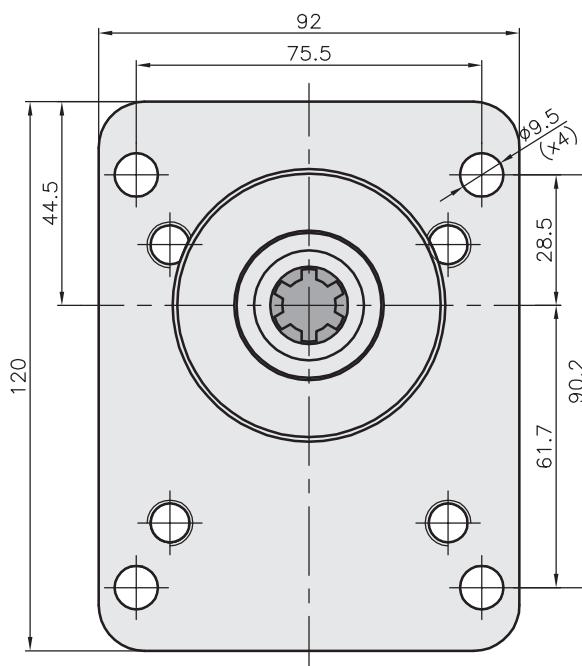

GRUPO  
**G1**

## TOMA DE FIJACIÓN F82 BOBCAT (Ø82.55)

Aplicable a bombas de 40 lts/min.

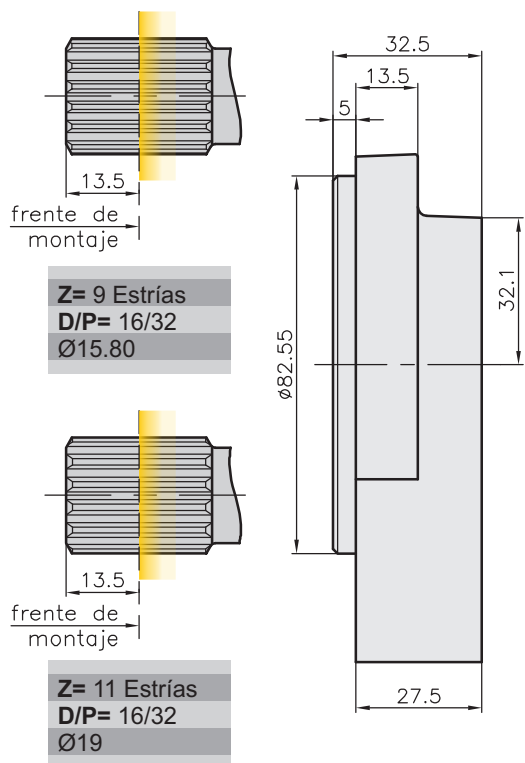

Z= 9 Estrías  
D/P= 16/32  
Ø15.80

Z= 11 Estrías  
D/P= 16/32  
Ø19

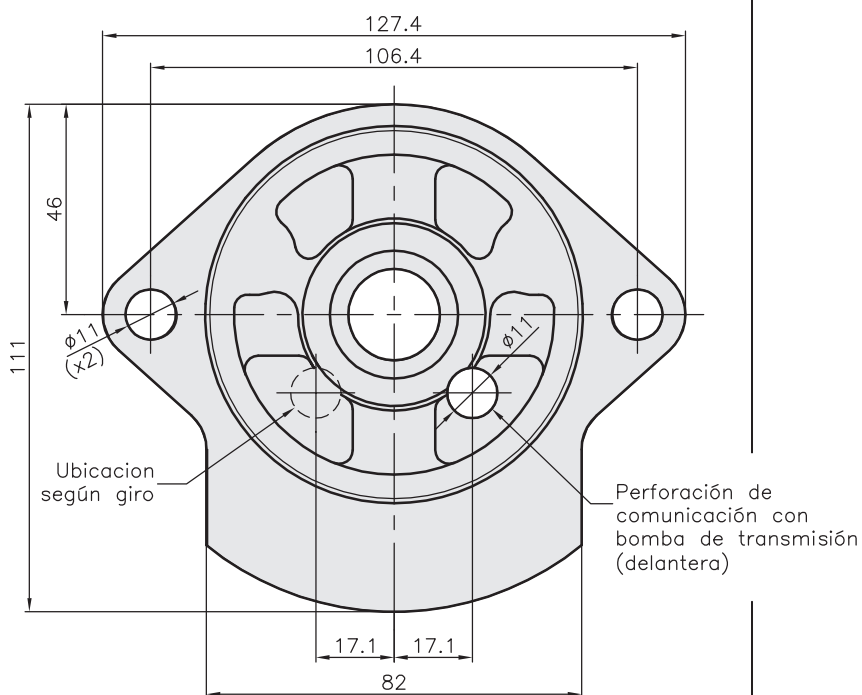

Ubicación según giro

Perforación de comunicación con bomba de transmisión (delantera)



## TOMA DE FIJACIÓN TRACTOR ZETOR (Ø62)

Aplicable a bombas de 45 lts/min.

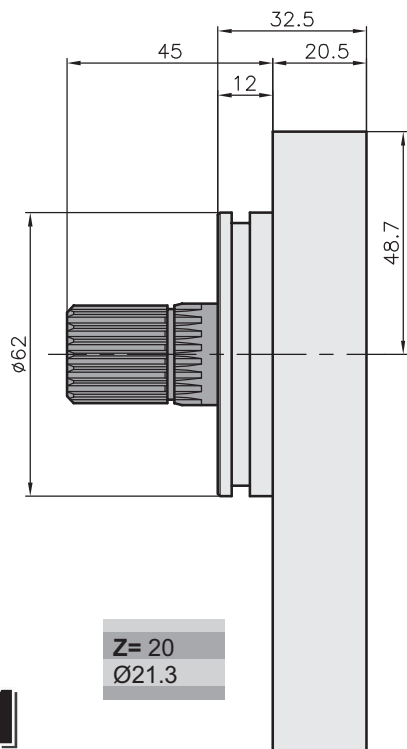

Z= 20  
Ø21.3

GRUPO  
**G1**

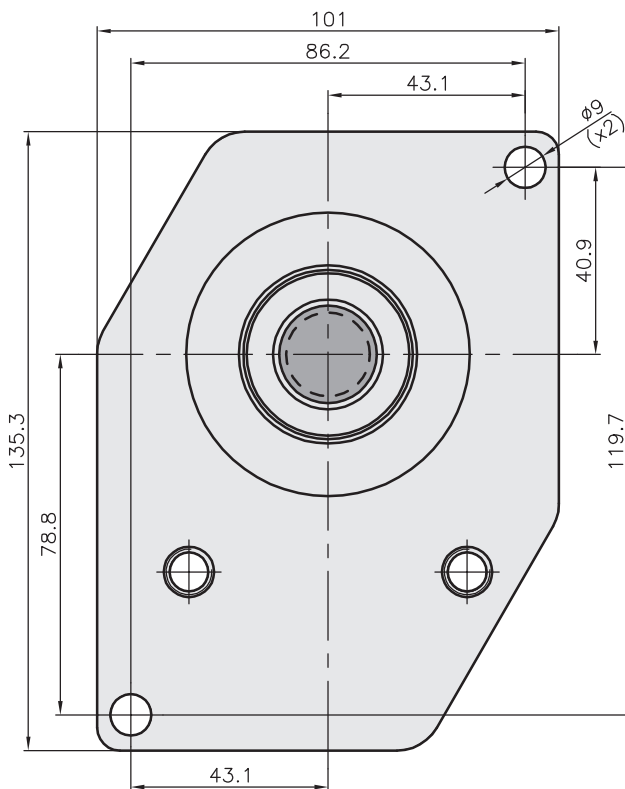

## TOMA DE FIJACIÓN TRACTOR CHINO (Ø38)

Aplicable a bombas de 32 lts/min.

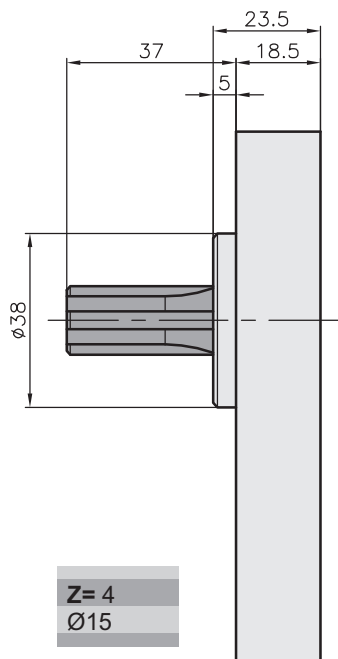

Z= 4  
Ø15

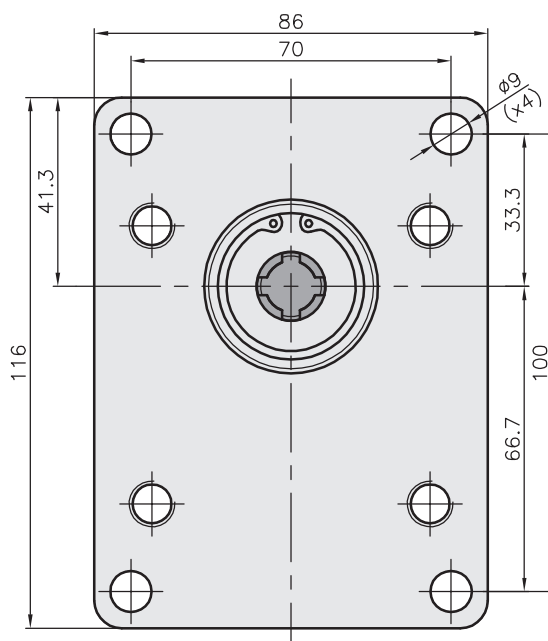



## ESTRIADO Z=9 (SAE)

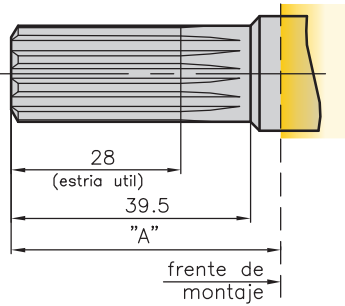

**DP= 16/32**  
**Ø= 15.8 mm**

## ESTRIADO Z=9 (DIN)

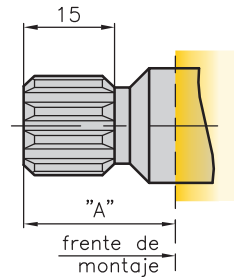

**Estria de envol.= B17x14**  
**Ø= 16.5 mm**

## ESTRIADO Z=10 (SAE)

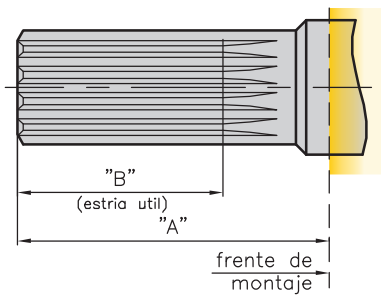

**DP= 16/32**  
**Ø= 17.4 mm**

TIPO DE BOMBA	COTA "B" (mm)
8 - 16 - 24 - 32	19
40 - 45 - 50 - 60	24

## ESTRIADO Z=10 (SAE) MIT

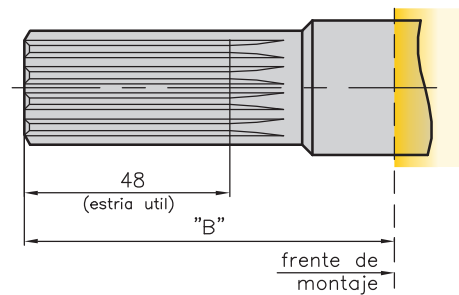

**DP= 16/32**  
**Ø= 17.4 mm**

GRUPO  
**G1**

## ESTRIADO Z=11 (SAE)

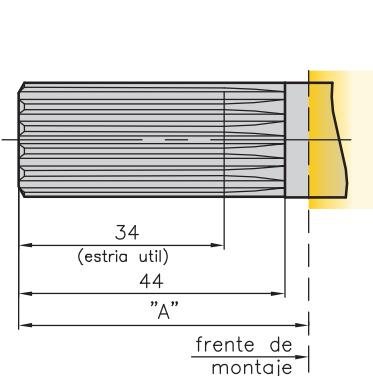

**DP= 16/32**  
**Ø= 19.05 mm**

## CÓNICO (CONO 1:5)

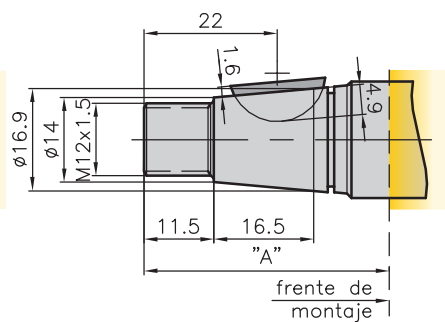

**Conicidad= 1:5**  
**Chav. Media Luna**  
**Ø16 x 3**

## CÓNICO DX-R (CONO 1:5)

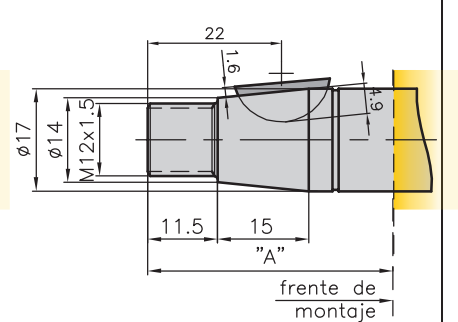

**Conicidad= 1:5**  
**Chav. Media Luna**  
**Ø16 x 3**





## CÓNICO (CONO 1:8)

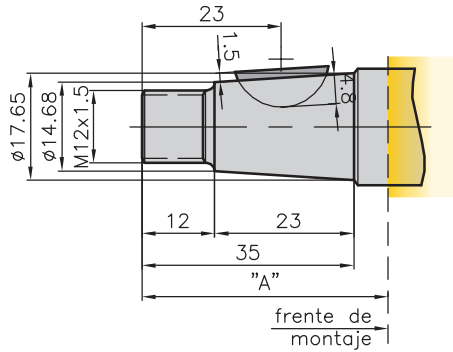

**Conicidad= 1:8**  
Chav. Media Luna  
Ø5/8" x 1/8"

## CILINDRICO Ø17.45 (11/16")

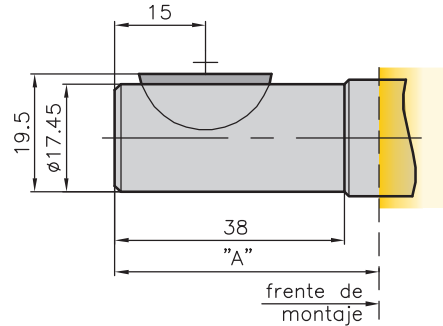

**Ø= 17.45 mm (11/16")**  
Chav. Media Luna  
Ø7/8" x 3/16"

## ESTRIADO Z=11 (SAE) BL

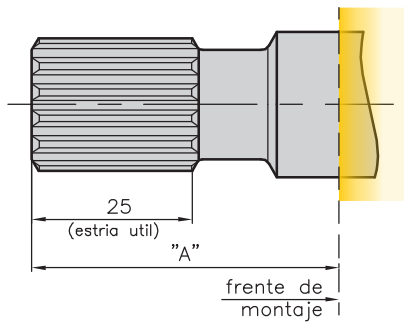

**DP= 16/32**  
**Ø= 19.05 mm**

## ESTRIADO Z=11 AGCO ALLIS

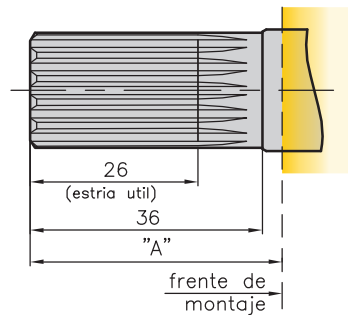

**DP= 16/32**  
**Ø= 17.95 mm**

**GRUPO G1**

EJES		DISTANCIA FRENTE MONTAJE A PUNTA DE ENGRANAJE (COTA "A")							CAUDALES ADMITIDOS								
		PL	DX	DX-R	F78	F82	F88	DR	DSR	8	16	24	32	40	45	50	60
EJES	Z=9 SAE	44.5	-	-	43.5	43.5	43.5	-	48.5	-	-	•	•	•	-	•	•
	Z=9 DIN	-	25.1	-	-	-	-	-	-	-	-	-	-	•	•	-	-
	Z=10 SAE	35/40	-	-	34/39	34/39	34/39	-	39/44	•	•	•	•	•	•	•	•
	Z=10 MIT	-	-	-	73	73	73	-	-	-	-	-	-	-	-	•	•
	Z=11 SAE	49	-	-	48	48	48	-	53	-	-	•	-	•	•	•	•
	C=1:5 CÓNICO	-	40.5	-	-	-	-	44	44	•	•	•	•	•	•	•	-
	C=1:5 DX-R	-	-	40.5	-	-	-	-	-	-	-	•	•	-	•	•	-
	C=1:8 CÓNICO	40	-	-	39	39	39	-	44	•	•	•	•	•	•	•	•
	Ø17.45	43	-	-	42	42	42	-	47	•	•	•	•	•	•	•	•
	Z=11 BL	-	-	-	-	37	-	-	-	-	-	-	-	-	•	•	-
	Z=11 AGCO	-	-	-	-	31	-	-	-	-	-	-	•	-	•	-	-



## CUERPO

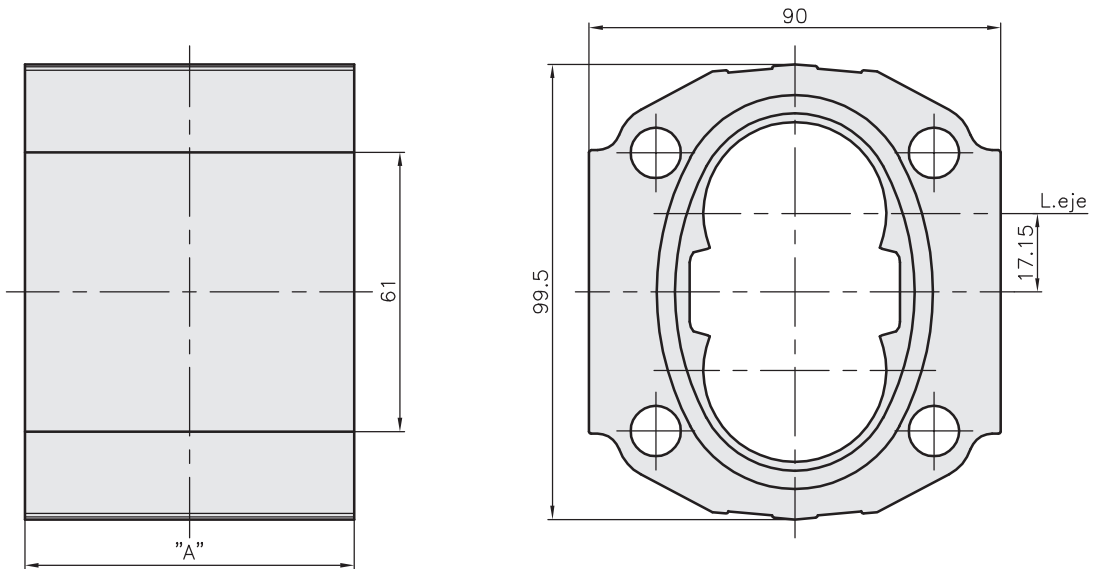

GRUPO  
**G1**

MODELO	COTA "A" (mm)
8-G1A	46.5
16-G1A	53
24-G1A	59.5
32-G1A	66
40-G1A	72
45-G1A	76
50-G1A	80
60-G1A	88

PERFORADOS ADMISIBLES																	
	CÓDIGO N° (SAE)	CUERPO ENTRADA LATERAL								CUERPO SALIDA LATERAL							
		8	16	24	32	40	45	50	60	8	16	24	32	40	45	50	60
PERF. (E)	8	•	•	•	•	•	•	•	•	•	•	•	•	•	•	•	•
	12	•	•	•	•	•	•	•	•	•	•	•	•	•	•	•	•
PERFORADO (E) Reb	8	-	-	•	•	•	•	•	•	-	-	•	•	•	•	•	•
	12	-	-	-	-	•	•	•	•	-	-	-	-	•	•	•	•
	16	-	-	-	-	-	•	•	•	-	-	-	-	-	•	•	•
	20	-	-	-	-	-	-	•	•	-	-	-	-	-	-	•	•
PERF. (P)	8	•	•	•	•	•	•	•	•	•	•	•	•	•	•	•	•
	12	•	•	•	•	•	•	•	•	•	•	•	•	•	•	•	•
	16	-	•	•	•	•	•	•	•	-	•	•	•	•	•	•	•
PERFORADO (S)	8	•	•	•	•	•	•	•	•	•	•	•	•	•	•	•	•
	10	•	•	•	•	•	•	•	•	•	•	•	•	•	•	•	•
	12	-	•	•	•	•	•	•	•	-	•	•	•	•	•	•	•
	14	-	-	-	•	•	•	•	•	-	-	-	•	•	•	•	•
16	-	-	-	•	•	•	•	•	-	-	-	•	•	•	•	•	



## CUERPO PL

Para bombas de 8 lts/min.

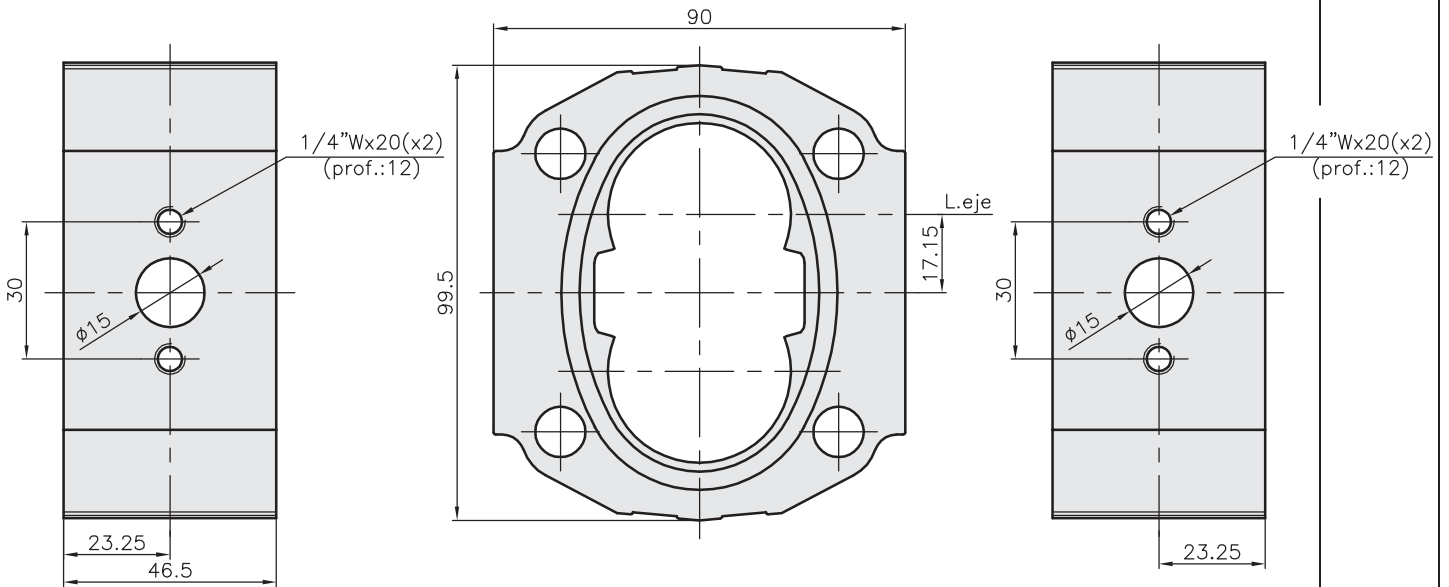

GRUPO  
**G1**

## CUERPO PL

Para bombas de 16, 24, 32, 40 y 45 lts/min.

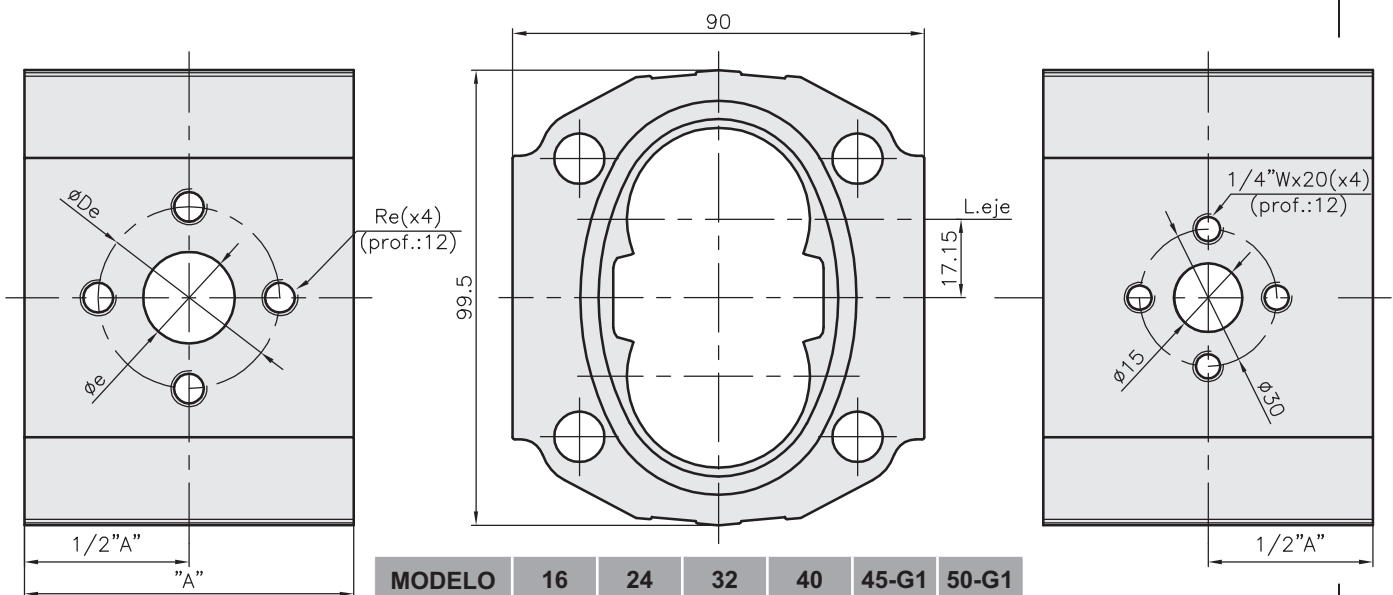

MODELO	16	24	32	40	45-G1	50-G1
COTA "A"	53	59.5	66	72	76	80
$\phi_e$	15	20	20	20	20	20
$\phi_{De}$	30	39.7	39.7	39.7	39.7	39.7
Re	1/4"W	5/16"W	5/16"W	5/16"W	5/16"W	5/16"W



## CUERPO PL

Para bombas de 45, 50 y 60 lts/min.

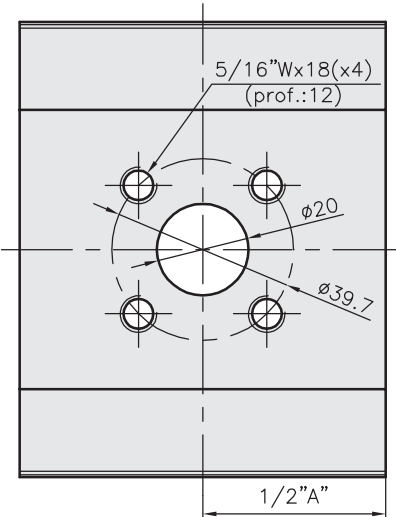
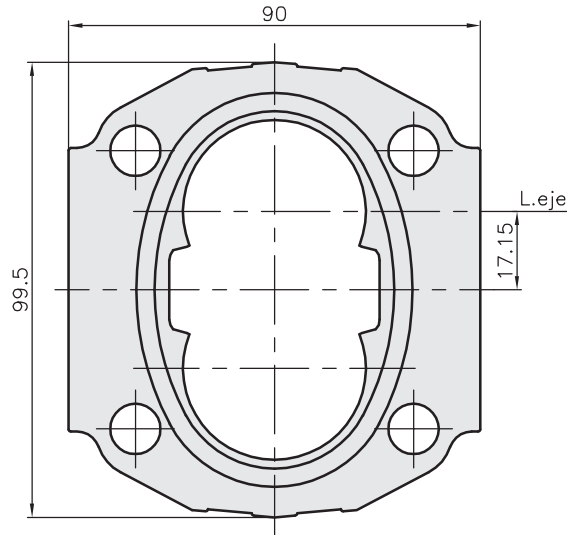
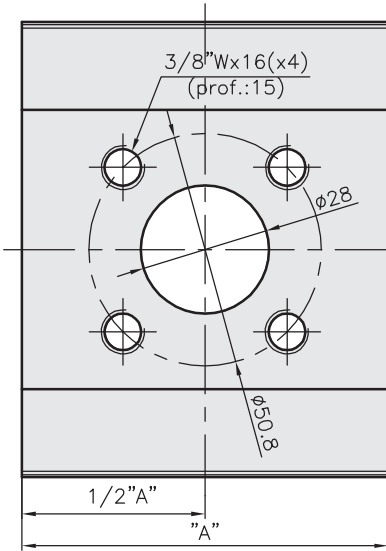

GRUPO  
**G1**

MODELO	45-G2	50-G2	60
COTA "A"	76	80	88

## CUERPO PL PARA SALIDA POSTERIOR

Para bombas de 8 lts/min.

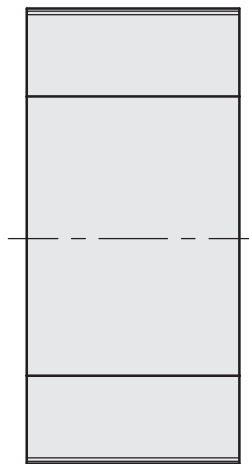
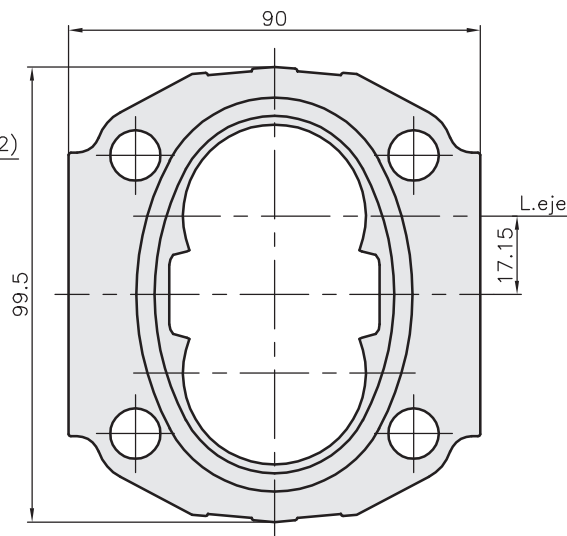
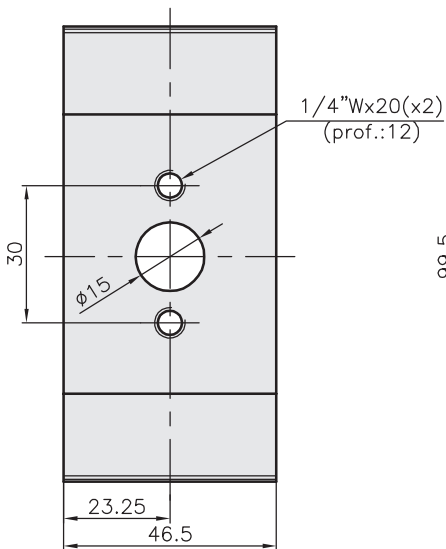



## CUERPO PL PARA SALIDA POSTERIOR

Para bombas de 16, 24, 32, 40 y 45 lts/min.

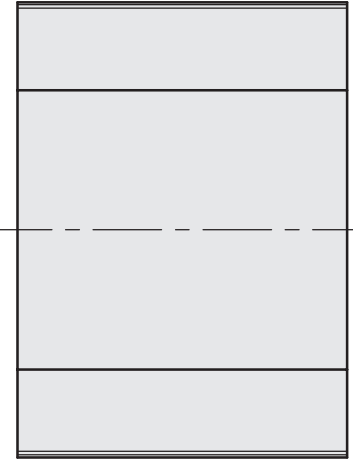
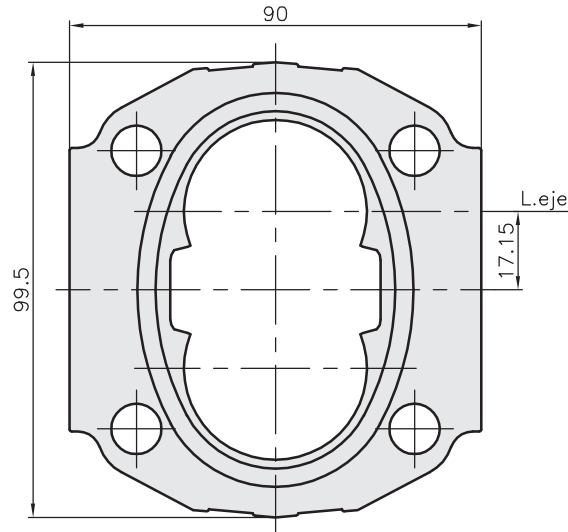
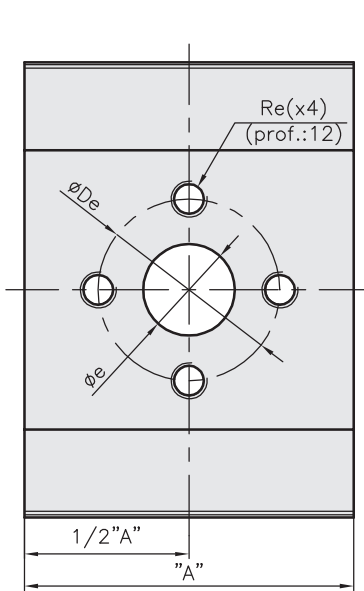

MODELO	16	24	32	40-G1	45-G1	50-G1
COTA "A"	53	59.5	66	72	76	80
$\varnothing e$	15	20	20	20	20	20
$\varnothing De$	30	39.7	39.7	39.7	39.7	39.7
Re	1/4"W	5/16"W	5/16"W	5/16"W	5/16"W	5/16"W

GRUPO  
**G1**

## CUERPO PL PARA SALIDA POSTERIOR

Para bombas de 45, 50 y 60 lts/min.

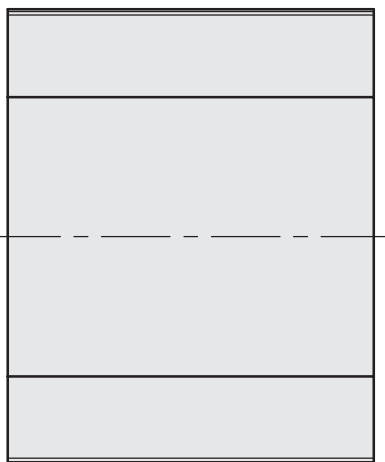
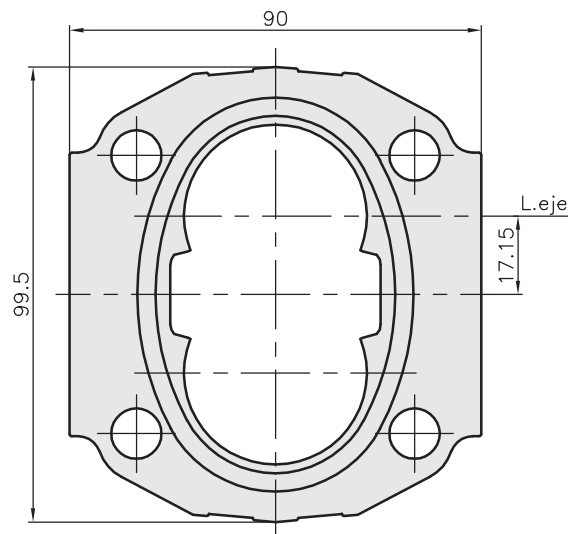
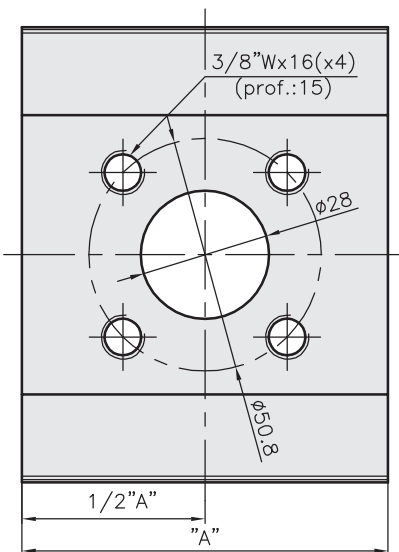

MODELO	45-G2	50-G2	60
COTA "A"	76	80	88



## CUERPO DEUTZ

Para bombas de 8, 16, 24, 32, 40, 45 y 50 lts/min.

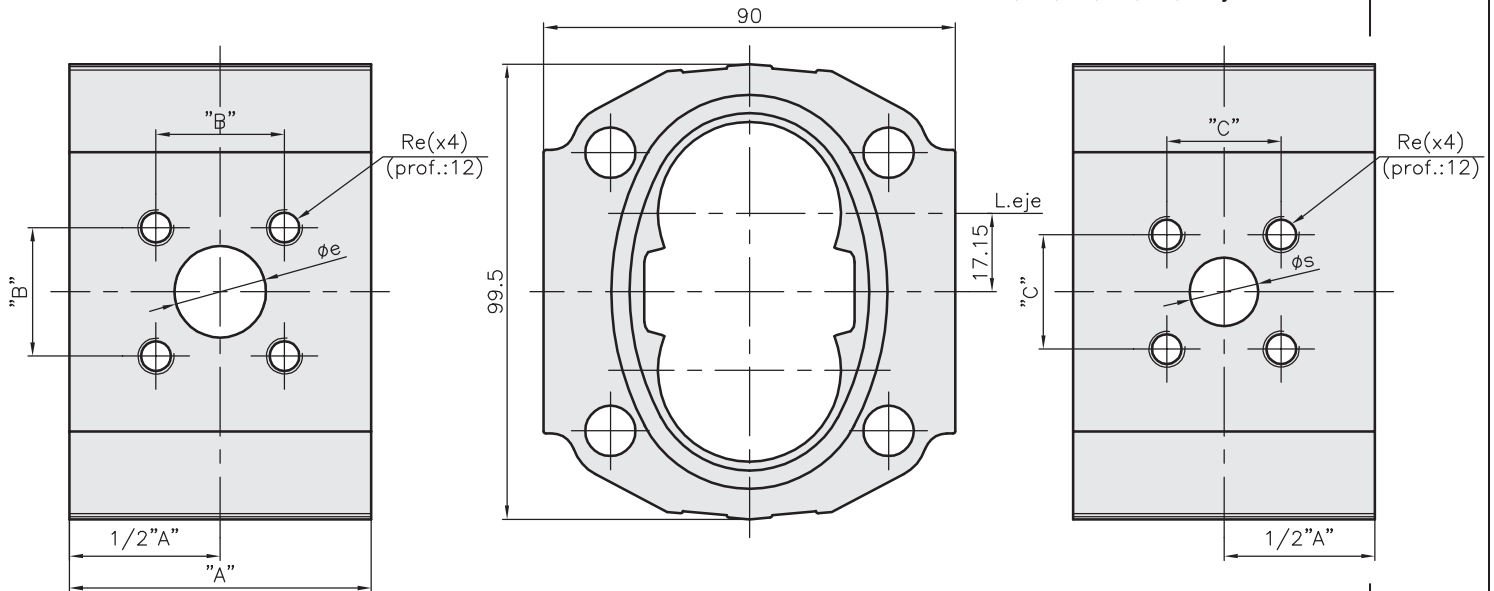

MODELO	8	16	24	32	40-B	40-V	45-B	45-V	50
COTA "A"	46.5	53	59.5	66	72	72	76	76	80
$\phi_e$	20	20	20	20	20	28	20	28	28
COTA "B"	28	28	28	28	28	35.9	28	35.9	35.9
$\phi_s$	15	15	15	15	15	20	15	20	20
COTA "C"	25	25	25	25	25	28	25	28	28
Re	M6x1	M6x1	M6x1	M6x1	M6x1	M8x1.25	M6x1	M8x1.25	M8x1.25

GRUPO  
**G1**

## CUERPO DEUTZ PARA SALIDA POSTERIOR

Para bombas de 24, 32, 40, 45 y 50 lts/min.

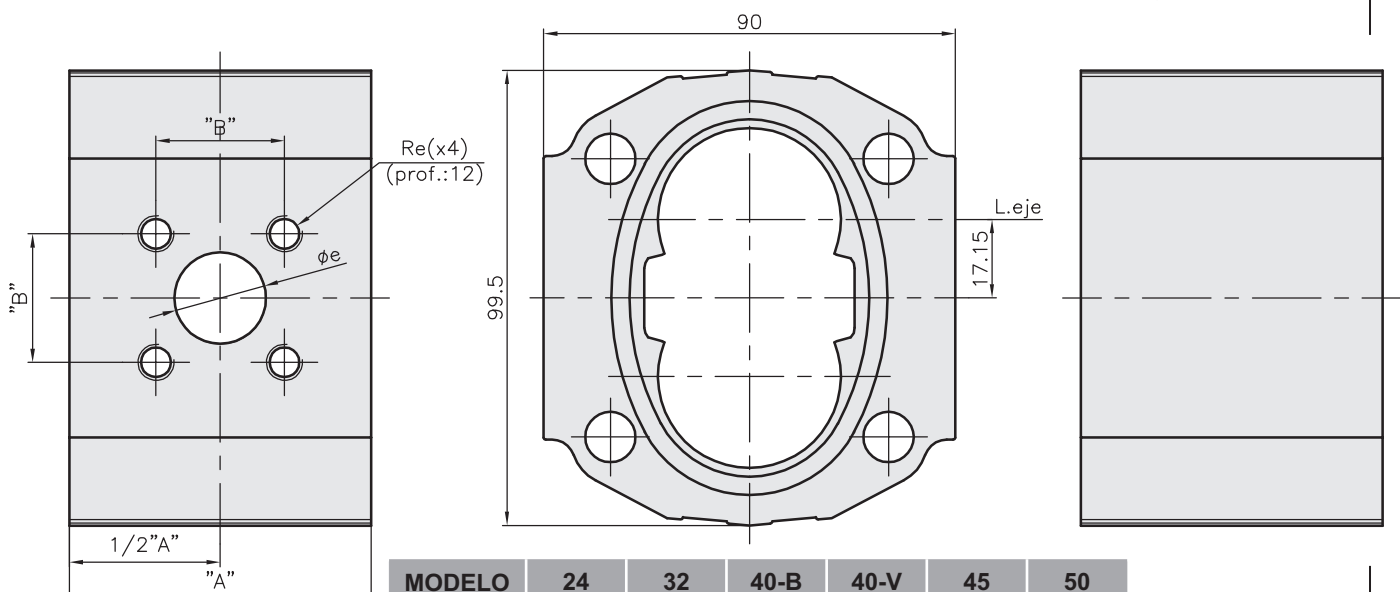

MODELO	24	32	40-B	40-V	45	50
COTA "A"	59.5	66	72	72	76	80
$\phi_e$	20	20	20	28	28	28
COTA "B"	28	28	28	35.9	35.9	35.9
Re	M6x1	M6x1	M6x1	M8x1.25	M8x1.25	M8x1.25





## CUERPO DEUTZ

Para bombas tandem 32/24 lts/min.  
Aplicable a tractores "DEUTZ" línea 5000

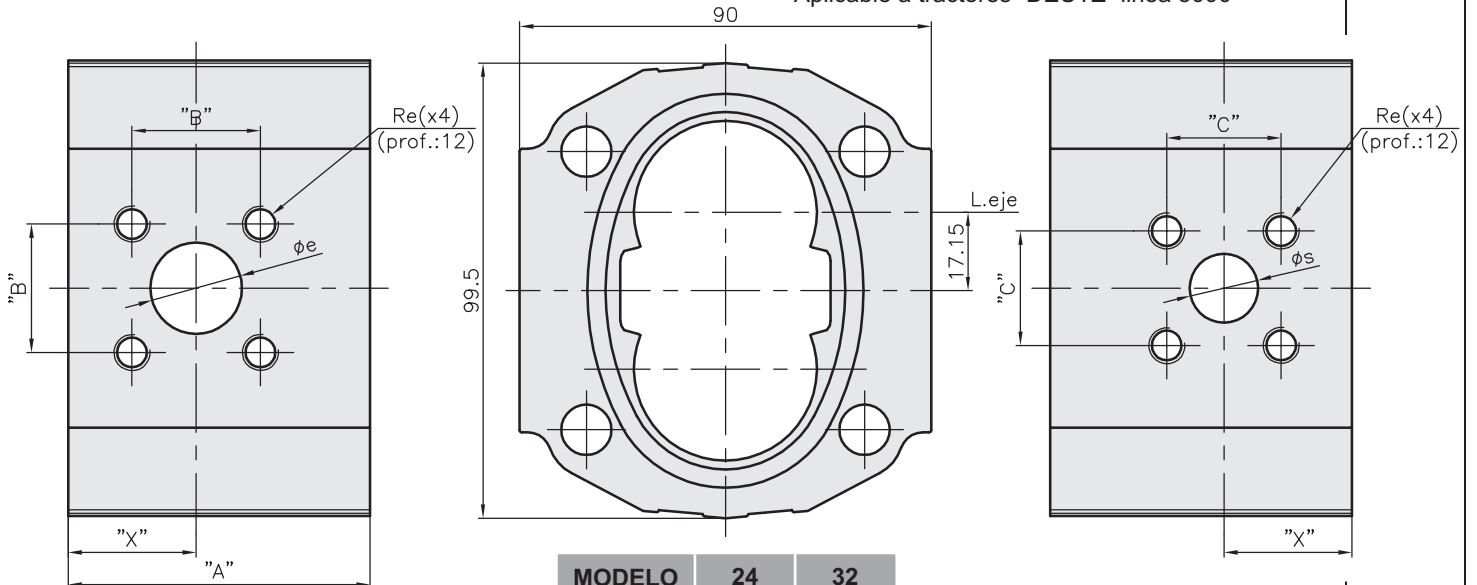

MODELO	24	32
COTA "A"	59.5	66
COTA "X"	36.3	28
øe	20	20
COTA "B"	28	28
øe	15	15
COTA "C"	25	25
Re	M6x1	M6x1

GRUPO  
**G1**

## CUERPO MF/1-MF/2

Para bombas de 24 lts/min.

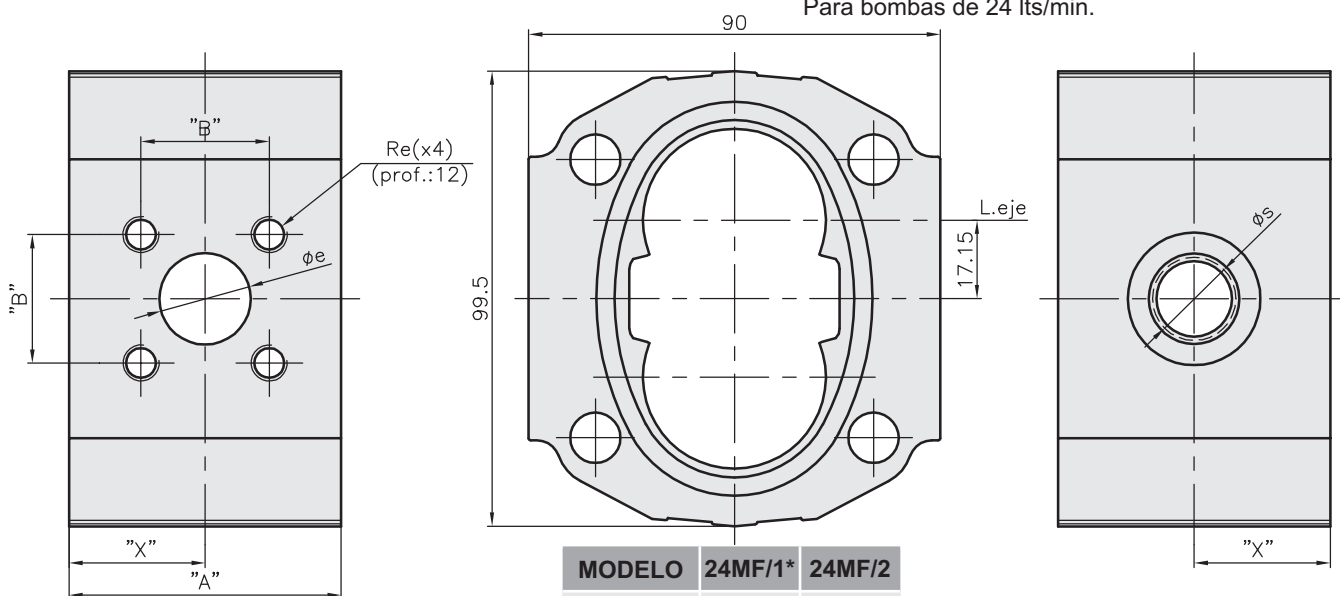

MODELO	24MF/1*	24MF/2
COTA "A"	59.5	59.5
COTA "X"	29.75	27
øe	20	20
COTA "B"	28	28
øe	-	M18x1.5
Re	M6x1	M6x1

(\* ) Corresponde salida por tapa posterior



## CUERPO VALMET (Motor CUMMINS)

Para bombas tandem de 45/24 lts/min.

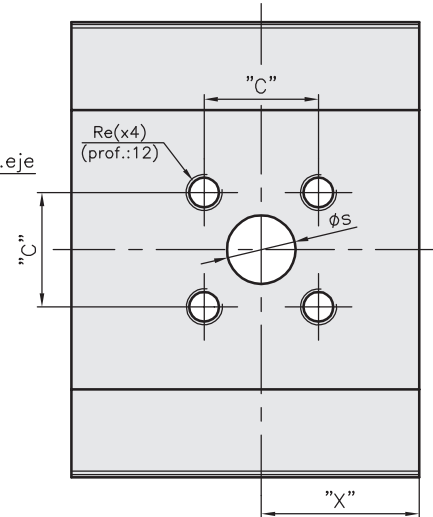
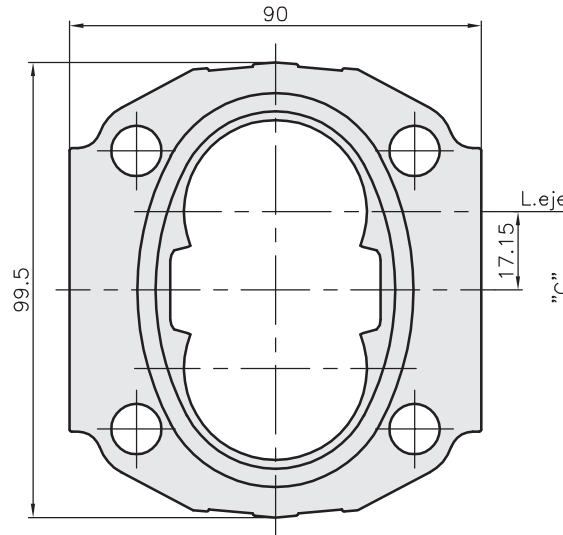
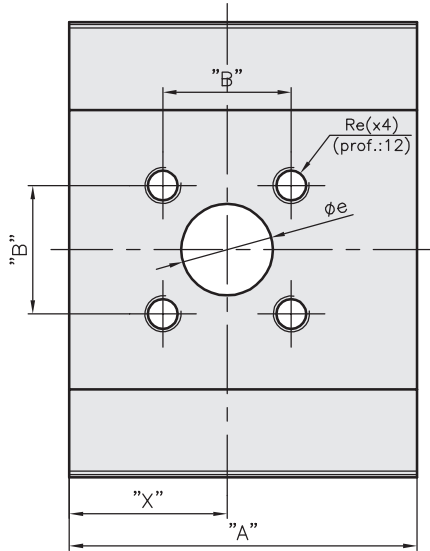

MODELO	24	45
COTA "A"	59.5	76
COTA "X"	32	34.5
$\phi_e$	20	20
COTA "B"	28	28
$\phi_s$	15	15
COTA "C"	25	25
Re	M6x1	M6x1

GRUPO  
**G1**

## CUERPO VALMET (Motor MWM)

Para bombas tandem de 45/32 lts/min.

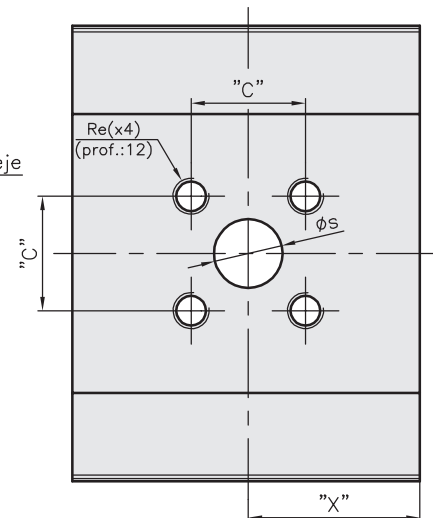
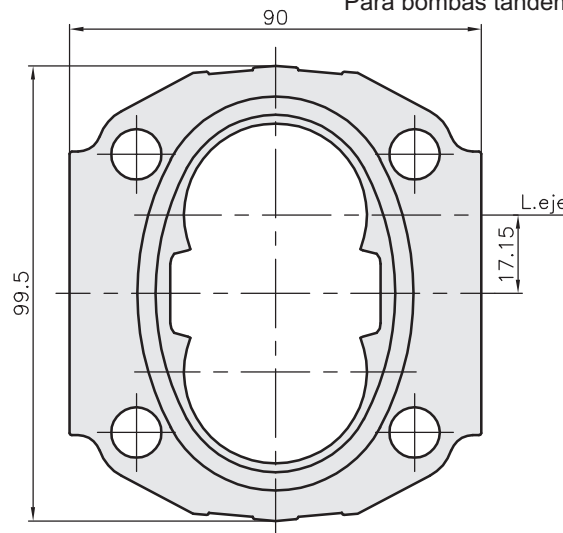
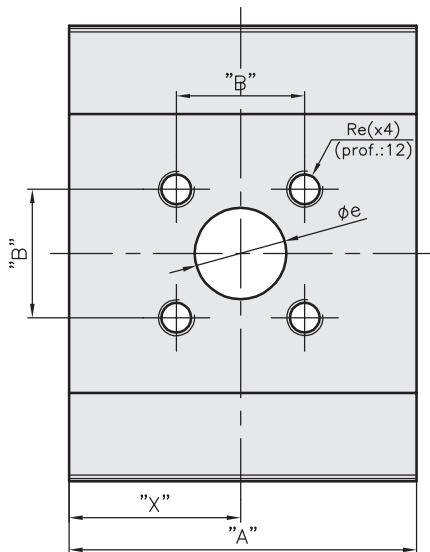

MODELO	32	45
COTA "A"	66	76
COTA "X"	39	37.5
$\phi_e$	20	20
COTA "B"	28	28
$\phi_s$	15	15
COTA "C"	25	25
Re	M6x1	M6x1



## CUERPO VALMET (Motor VALMET)

Para bombas tandem de 45/32 lts/min.

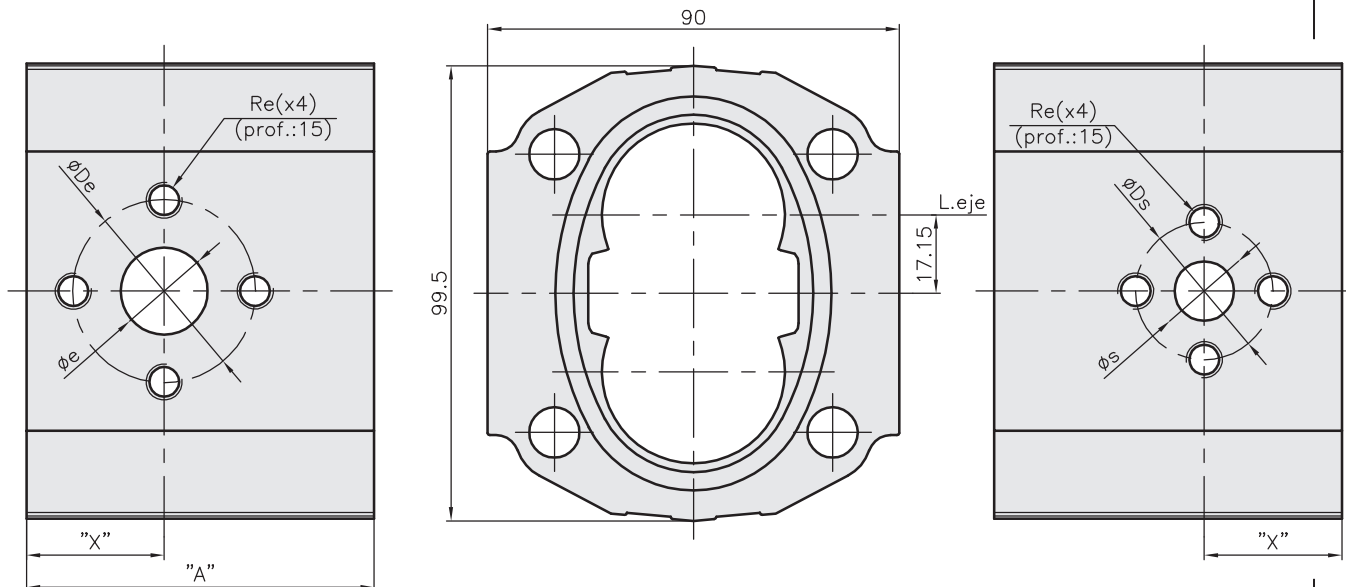

GRUPO  
**G1**

MODELO	32	45
COTA "A"	66	76
COTA "X"	35.4	30.1
Øe	19	19
ØDe	40	40
Øs	13	13
ØDs	30	30
Rs	M6x1	M6x1
Re	M8x1.25	M8x1.25



## INTERMEDIARIO TANDEM G1 / G1

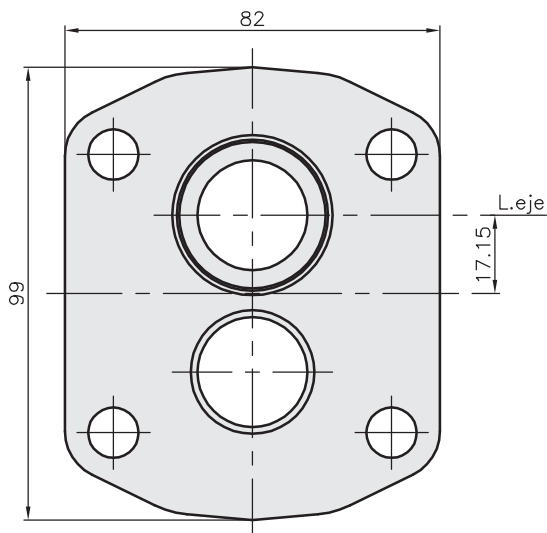
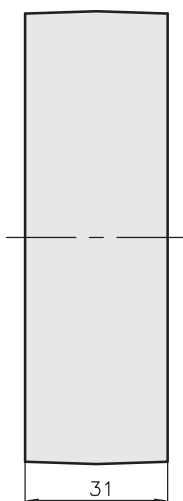

GRUPO  
**G1**

## INTERMEDIARIO TANDEM G1 / G1

Para bombas independientes.

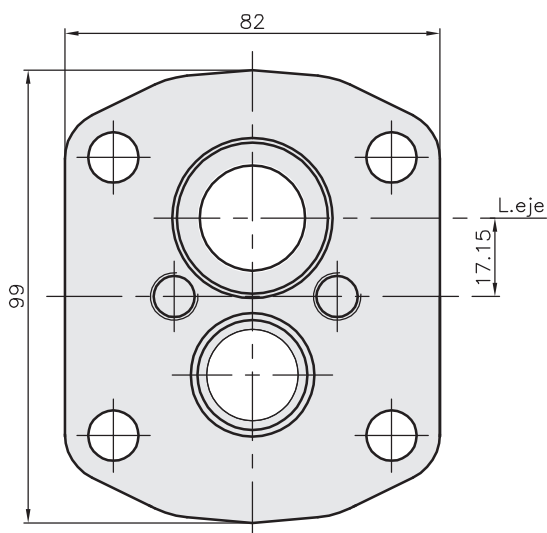
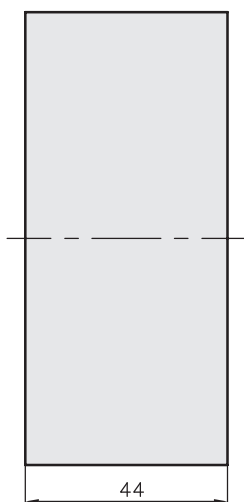



## TAPA POSTERIOR STANDARD

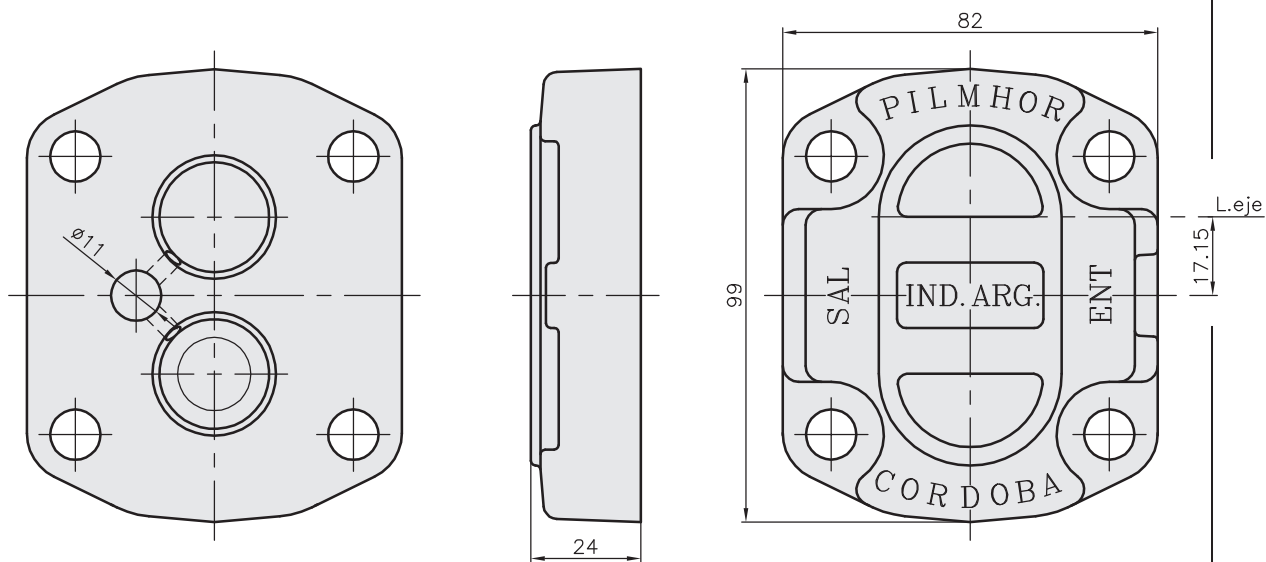

GRUPO  
**G1**

## TAPA POSTERIOR PARA MOTORES BIDIRECCIONALES

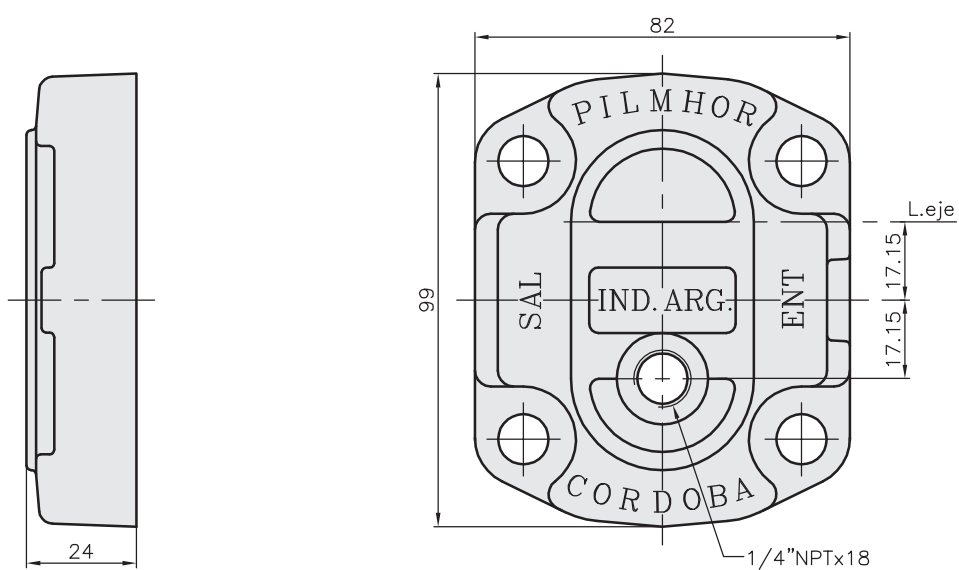



## TAPA POSTERIOR PARA MOTORES UNIDIRECCIONALES

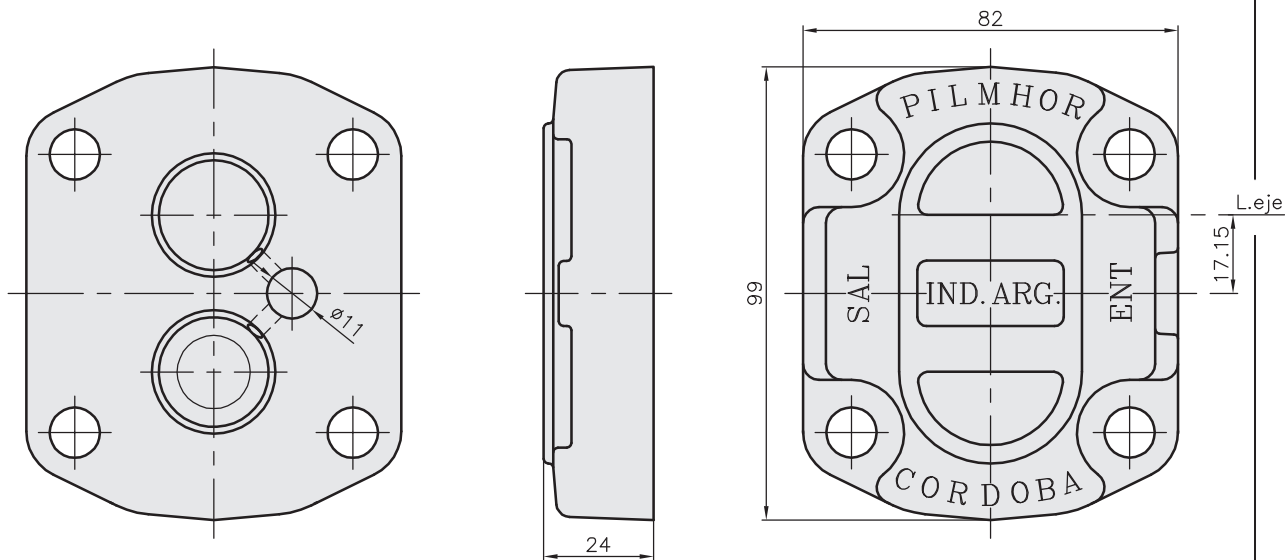

GRUPO  
**G1**

## TAPA POSTERIOR CON VALVULA

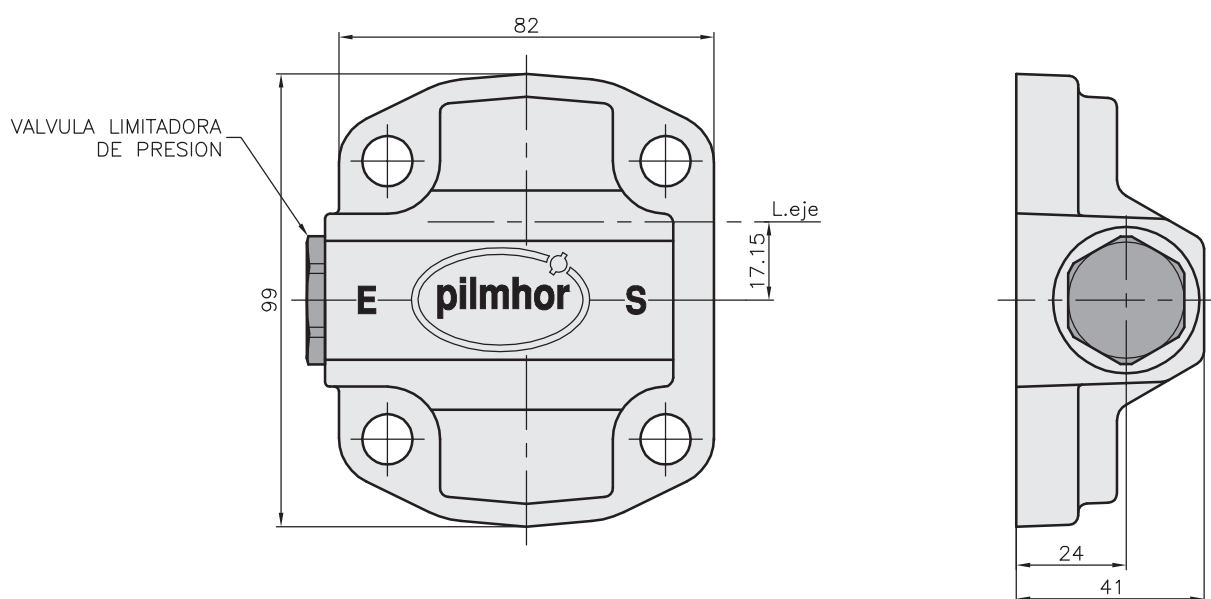

**NOTA:** PARA CALIBRACIONES INFERIORES A 20 bar CONSULTAR A NUESTRO DEPARTAMENTO DE INGENIERÍA



## TAPA POSTERIOR CON ENTRADA Y SALIDA POSTERIOR

Pasaje máximo de caudal 35 lts/min.

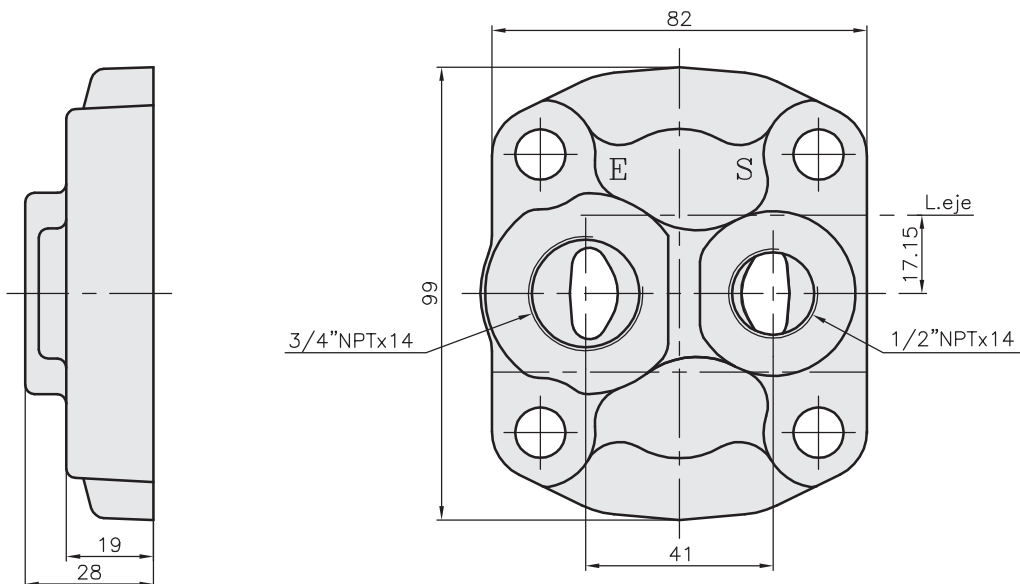

GRUPO  
**G1**

## TAPA POSTERIOR CON ENTRADA Y SALIDA POSTERIOR PARA MOTORES BIDIRECCIONALES

Pasaje máximo de caudal 35 lts/min.

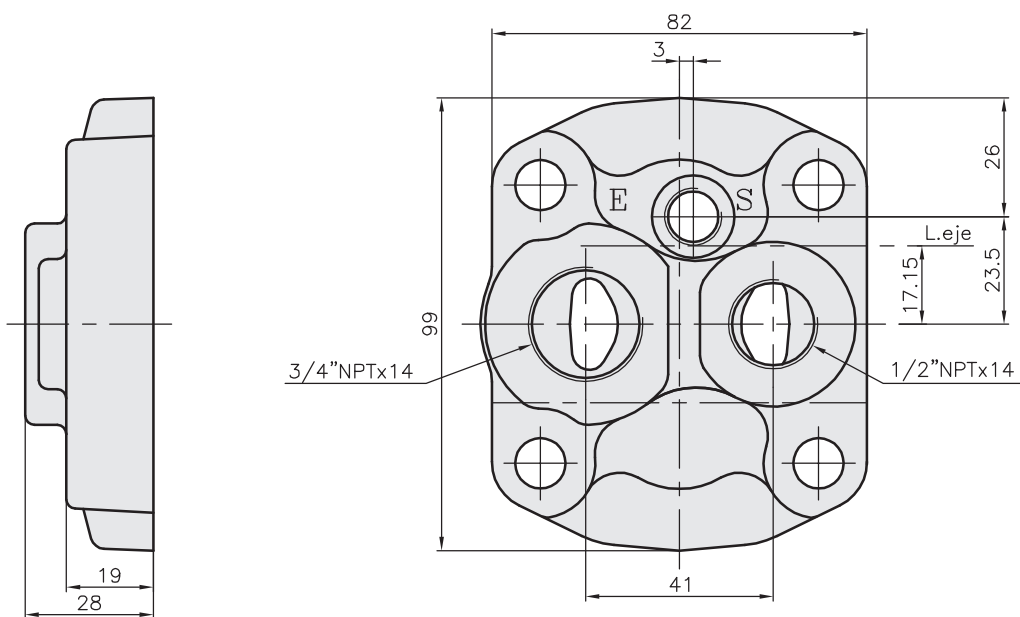



## TAPA POSTERIOR 12MF

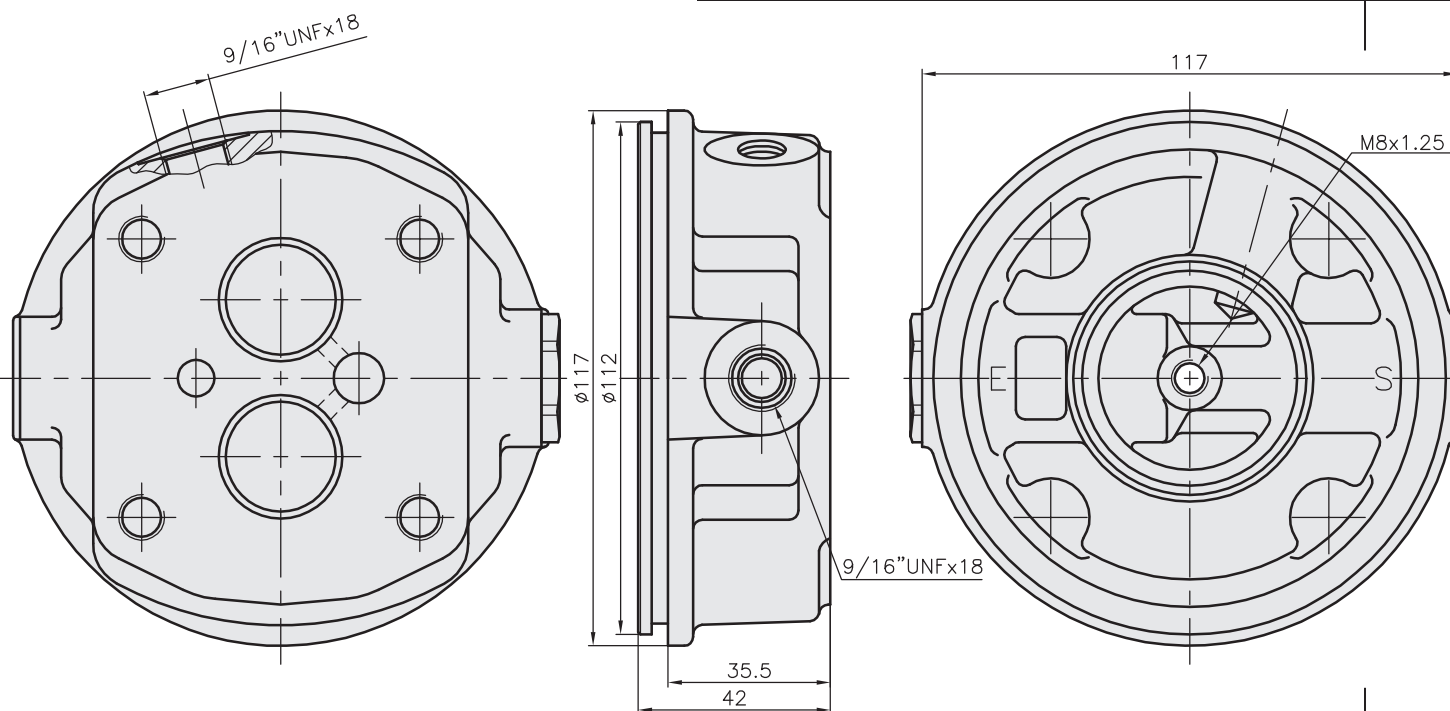

GRUPO  
**G1**

## TAPA POSTERIOR CON VALVULA 24MF/1

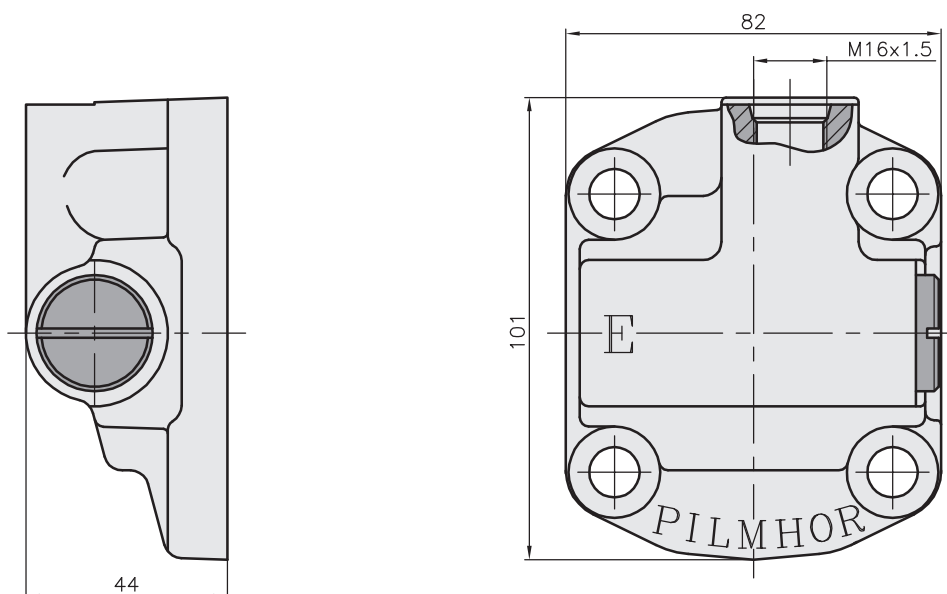





## TAPA POSTERIOR DE CAUDAL CONSTANTE

Pasaje máximo de caudal 40 lts/min.

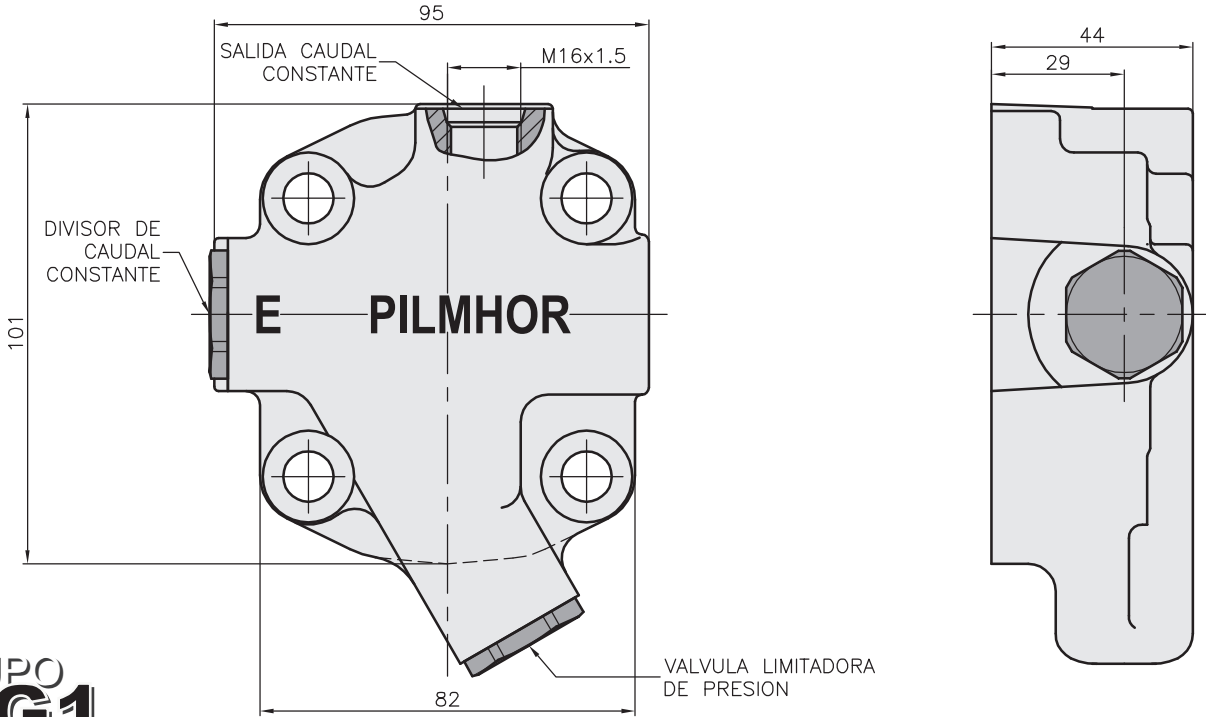

GRUPO  
**G1**

## TAPA POSTERIOR DE CAUDAL W1

Pasaje máximo de caudal salida primario 30 lts/min.  
Pasaje máximo de caudal total 50 lts/min.

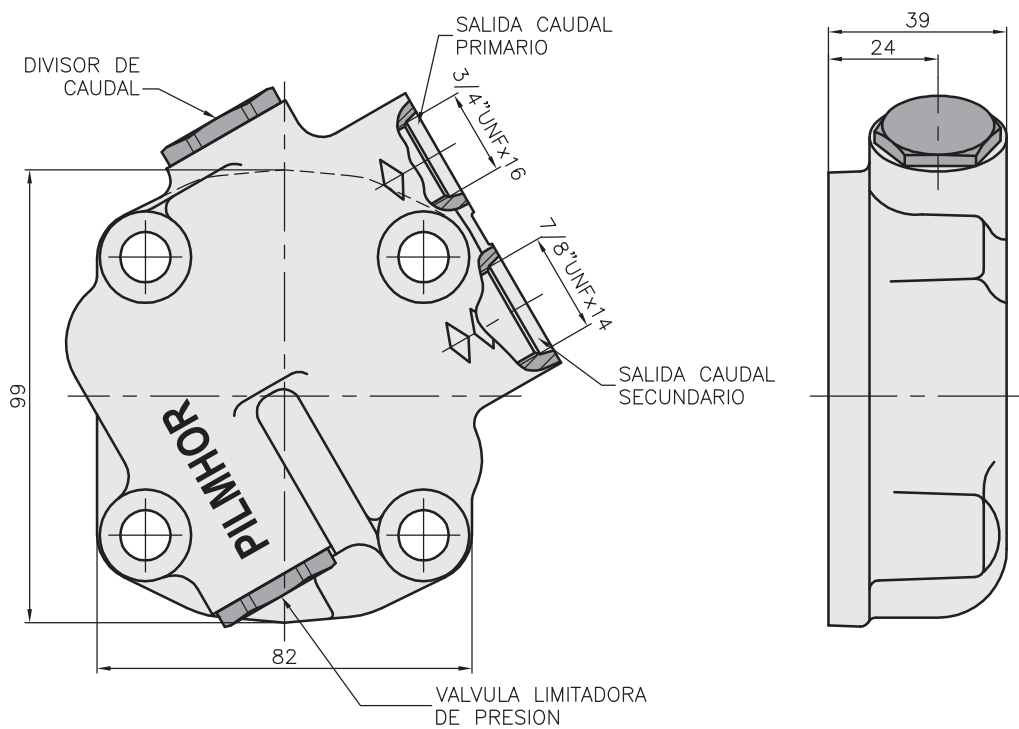



## TAPA POSTERIOR DE CAUDAL W1P

Pasaje máximo de caudal salida primario 30 lts/min.  
Pasaje máximo de caudal total 50 lts/min.

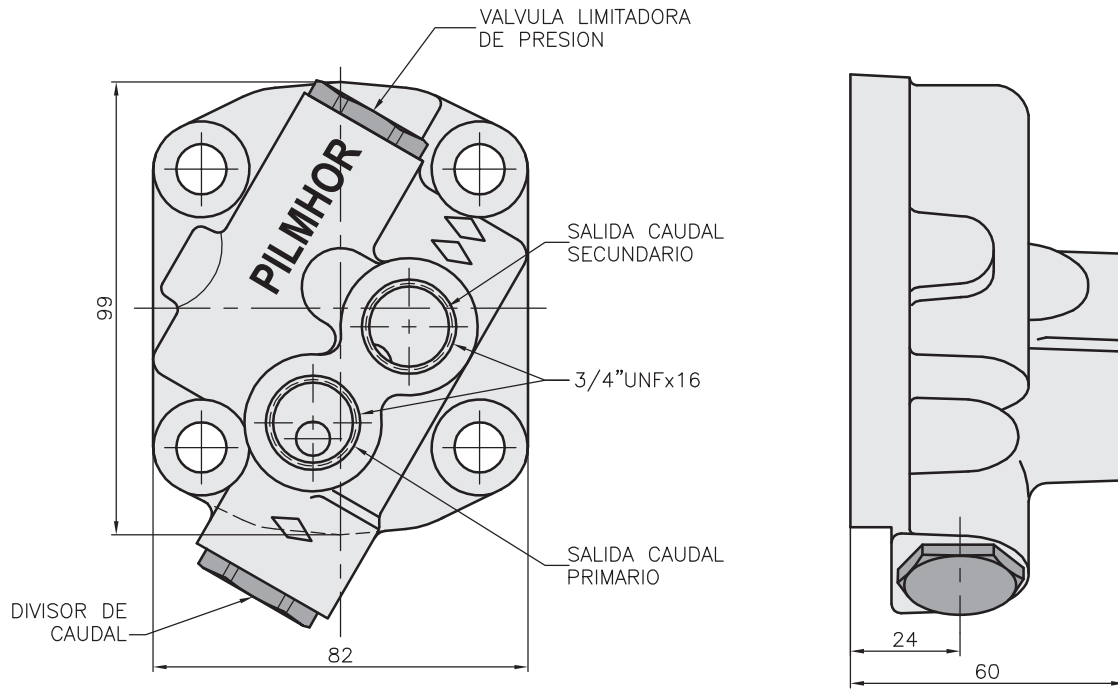

NOTA: la tapa posterior de caudal W1P puede ser reformada para ser utilizada como tapa caudal constante salida posterior.

GRUPO  
**G1**

## BRIDAS ROSCADAS

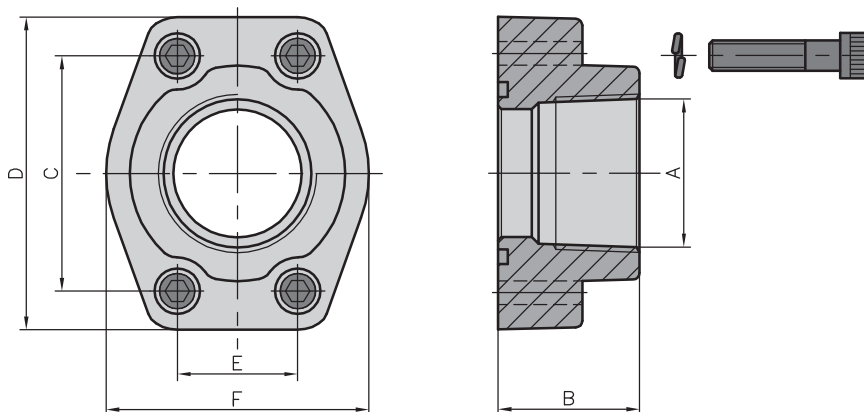

MEDIDA SAE	DIMENSIONES					
	ROSCA (A)	B	C	D	E	F
3/4"	3/4" NPTx14	35	47.63	65	22.23	44
1"	1" NPTx11 1/2	35	52.37	70	26.19	51
(* )1 1/4"	1 1/4" NPTx11 1/2	40	58.72	79	30.18	63



## PERFORADO SAE STANDARD

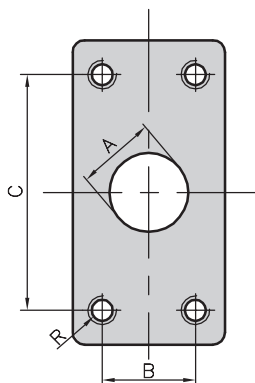

### CÓDIGO DEL PERFORADO (F)

NOMINAL (OD TUBE)	A (mm)	B (mm)	C (mm)	R (mm)	CÓDIGO N° (SAE)
1/2"	12.70	17.47	38.10	5/6" UNCx18	<b>8</b>
(* )3/4"	19.05	22.22	47.62	3/8" UNCx16	(* ) <b>12</b>

EJEMPLO: PERFORADO SAE STANDARD "F12" CORRESPONDE A NOMINAL (\* ) 3/4", DEBIENDOSE ACLARAR SI PERTENECE A ENTRADA O SALIDA.

## PERFORADO SAE STANDARD REBATIDO

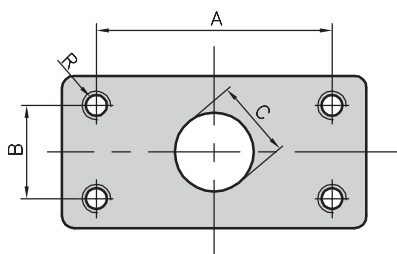

### CÓDIGO DEL PERFORADO (F) Reb

NOMINAL (OD TUBE)	A (mm)	B (mm)	C (mm)	R (mm)	CÓDIGO N° (SAE)
1/2"	38.10	17.47	12.70	5/6" UNCx18	<b>8</b>
3/4"	47.62	22.22	19.05	3/8" UNCx16	<b>12</b>
1"	52.37	26.18	25.40	3/8" UNCx16	<b>16</b>
(* )1 1/4"	58.72	30.17	31.75	7/16" UNCx14	(* ) <b>20</b>

EJEMPLO: PERFORADO SAE STANDARD "F20" CORRESPONDE A NOMINAL (\* ) 1 1/4", DEBIENDOSE ACLARAR SI PERTENECE A ENTRADA O SALIDA.

GRUPO  
**G1**

## PERFORADO CON ROSCA CÓNICA

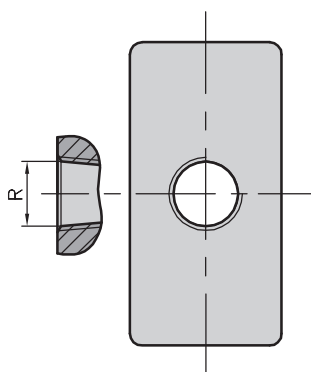

### CÓDIGO DEL PERFORADO (P)

NOMINAL (OD TUBE)	ROSCA R	CÓDIGO N° (SAE)
1/2"	1/2" NPTx14	<b>8</b>
3/4"	3/4" NPTx14	<b>12</b>
(* ) 1"	1" NPTx11 1/2	(* ) <b>16</b>

EJEMPLO: PERFORADO C/ROSCA CONICA "P16" CORRESPONDE A NOMINAL (\* ) 1", DEBIENDOSE ACLARAR SI PERTENECE A ENTRADA O SALIDA.

## PERFORADO CON ROSCA CILÍNDRICA PARA AROSELLO

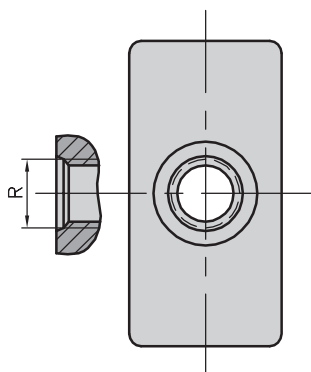

### CÓDIGO DEL PERFORADO (S)

NOMINAL (OD TUBE)	ROSCA R	CÓDIGO N° (SAE)
1/2"	3/4" UNFx16	<b>8</b>
5/8"	7/8" UNFx14	<b>10</b>
3/4"	1 1/16" UNFx12	<b>12</b>
7/8"	1 3/16" UNFx12	<b>14</b>
(* ) 1"	1 5/16" UNFx12	(* ) <b>16</b>

EJEMPLO: PERFORADO C/ROSCA CILINDRICA "S16" CORRESPONDE A NOMINAL (\* ) 1", DEBIENDOSE ACLARAR SI PERTENECE A ENTRADA O SALIDA.



## MANGUITO Z=10

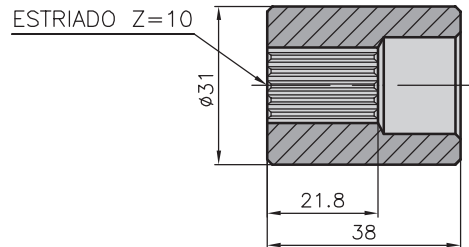

Z= 10 SAE  
 DP= 16/32  
 Ø= 17.46 mm

## MANGUITO Z=11

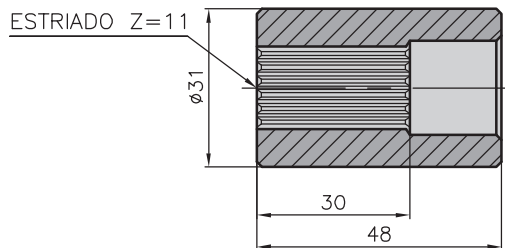

Z= 11 SAE  
 DP= 16/32  
 Ø= 19.05mm

GRUPO  
**G1**

## MANGUITO MI Z=10 - Z=14

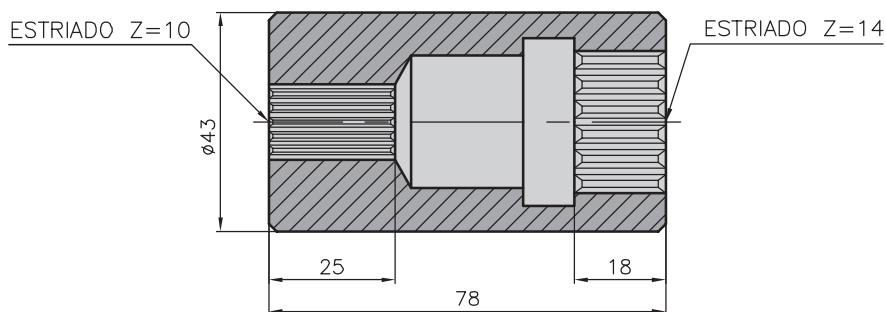

Z= 10 SAE  
 DP= 16/32  
 Ø= 17.46 mm

Z= 14 SAE  
 DP= 12/24  
 Ø= 31.75 mm



## MANGUITO TF Z=10 - Z=15

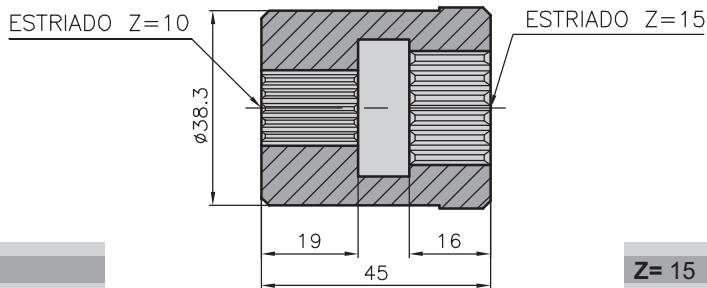

Z= 10 SAE  
DP= 16/32  
Ø= 17.46 mm

Z= 15 SAE  
DP= 16/32  
Ø= 25.40 mm

## MANGUITO Z=30 - Z=10 VALMET (Motor MWM)

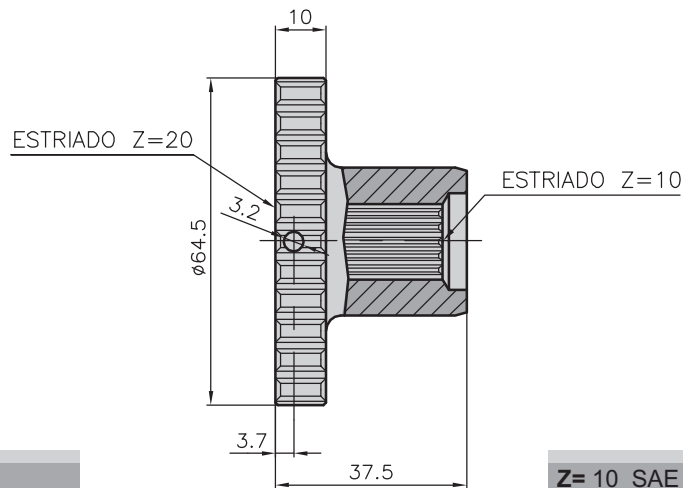

Z= 30 SAE  
MODULO= 2  
Ø= 64.20 mm

Z= 10 SAE  
DP= 16/32  
Ø= 17.46 mm

## MANGUITO Z=10 VALMET (Motor CUMMINS)

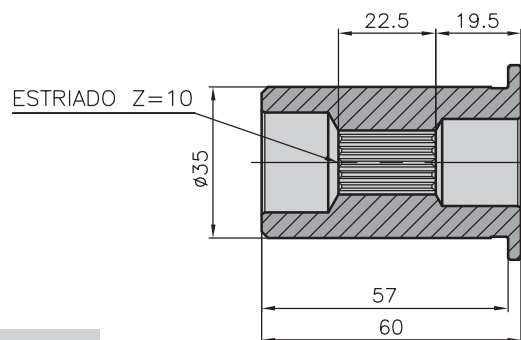

Z= 10 SAE  
DP= 16/32  
Ø= 17.46mm

GRUPO  
**G1**



## CODO A 90° 3/4"NPT

**ENTRADA:** 24 - 32 - 40 - 45 lts/min.

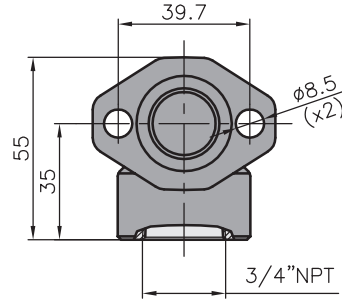
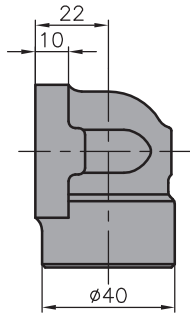

## CODO A 90° 1/2"NPT

**ENTRADA:** 8 - 16 lts/min.

**SALIDA:** 8 - 16 - 24 - 32 - 40 - 45 lts/min.

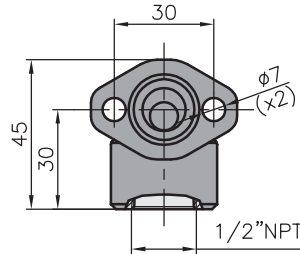
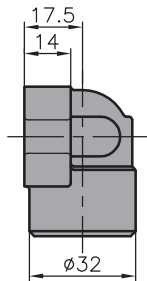

GRUPO  
**G1**

## CODO A 45° 1"NPT

**ENTRADA:** 50 - 60 lts/min.

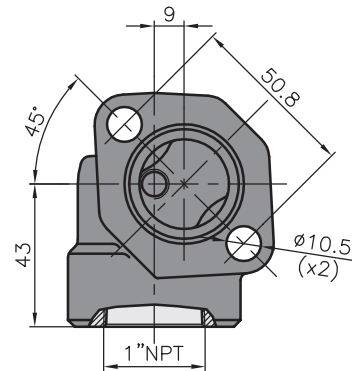
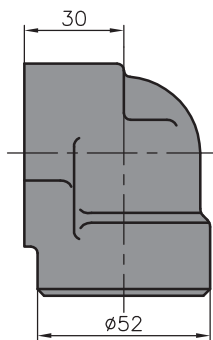

## CODO A 45° 3/4"NPT

**SALIDA:** 50 - 60 lts/min.

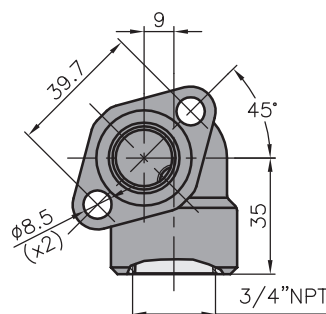
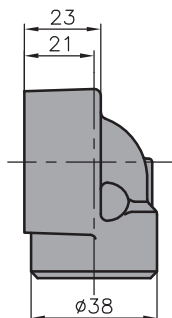



1

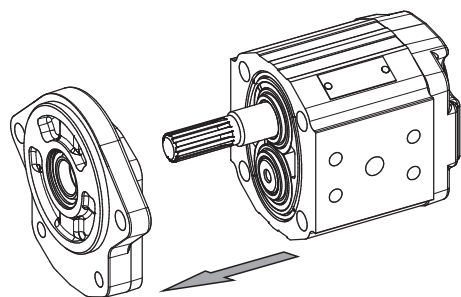

2

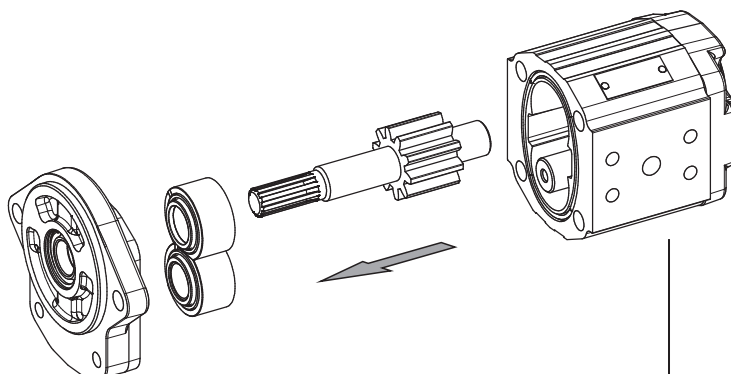

3

GRUPO  
**G1**

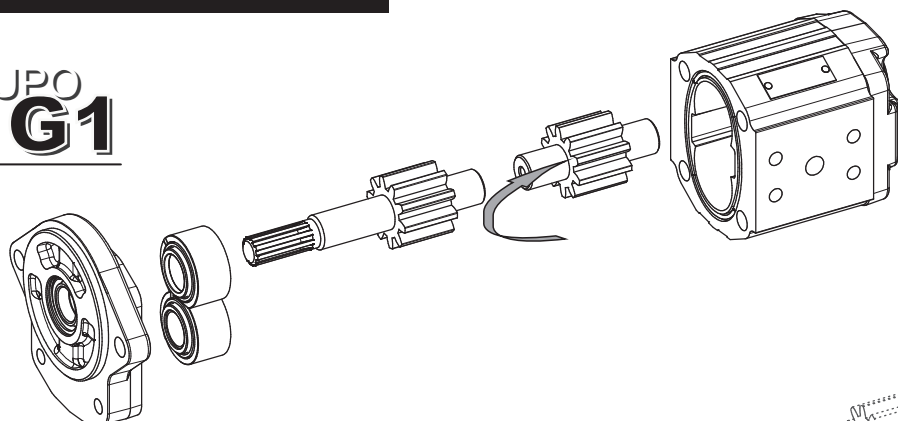

4

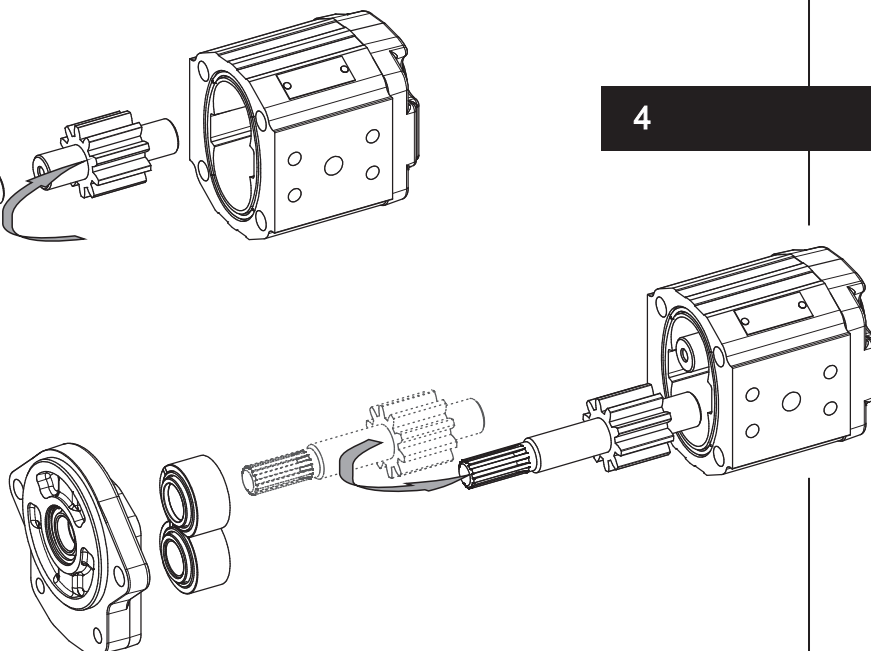

5

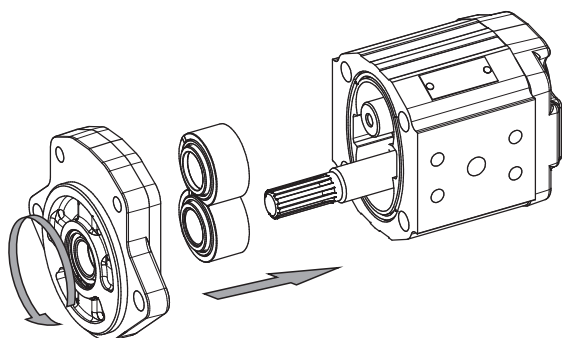

6

