



oleohidráulica

www.pilmhor.com.ar

Bombas y Motores de engranajes



GRUPO P 250

Caudales de 40 a 200 lts/min a 2000 rpm

Presiones hasta 250 bar
Motores hasta 80 hp

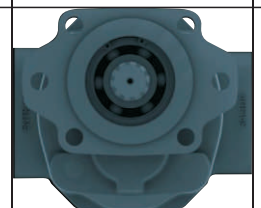
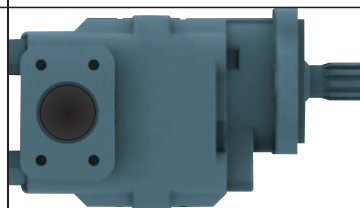



Se trata de un conjunto de bombas y motores de engranajes de alta presión, hasta 250 bar, que abarca caudales de 40 / 60 / 80 / 100 / 120 / 140 / 160 / 180 / 200 lts/min a 2000 rpm.

Construida íntegramente en **fundición de hierro**.

Su cuerpo, de **fundición de nodular**, posee propiedades que mejoran sus cualidades anti-fricción. Así mismo, los bajos niveles de desgaste permiten obtener rendimientos superiores al 95% y responder a las mayores exigencias de funcionamiento de los circuitos.

Los engranajes, apoyan sobre **casquillos de fricción** de 40mm de longitud y están compensados hidráulicamente con **placas anti-fricción de aleación de bronce**.

Para la dimensiones de montaje se utilizan como guía de referencia las **normativas SAE**.

Es posible armar **unidades múltiples: P250 / P250, P250 / G15 y P250 / G1**, lo que permite seleccionar diversas **combinaciones de caudales**, como así también, disponer versiones de **tapas posteriores** tanto en el **grupo G15** como en **grupo G1**.

Para la correcta elección de una bomba se debe considerar la presión de trabajo, necesidad de caudal real, dimensiones de montaje, potencia absorbida, características del actuador, espacio físico, etc.

Las aplicaciones mas importantes del **grupo P-250** son:

Tractores, topadoras, palas cargadoras, moto niveladoras, retro excavadoras, centrales hidráulicas, prensas hidráulicas, barcos pesqueros, industria petrolera, maquinaria aplicada a la minería, etc.

Recomendaciones:

- Utilizar aceite hidráulico específico.
- Utilizar filtros, tanto de succión como de retorno, apropiado y debidamente dimensionados.
- Asegúrese que el circuito tenga la velocidad de circulación del fluido correcta, evitando cavitación en la succión.
- Evitar sobrepresiones (picos de presión) que superen los límites permitidos recomendados.
- Asesórese y consulte, a nuestro Departamento de Ingeniería cuando lo considere necesario.





BOMBA GRUPO P250

GRUPO P 250

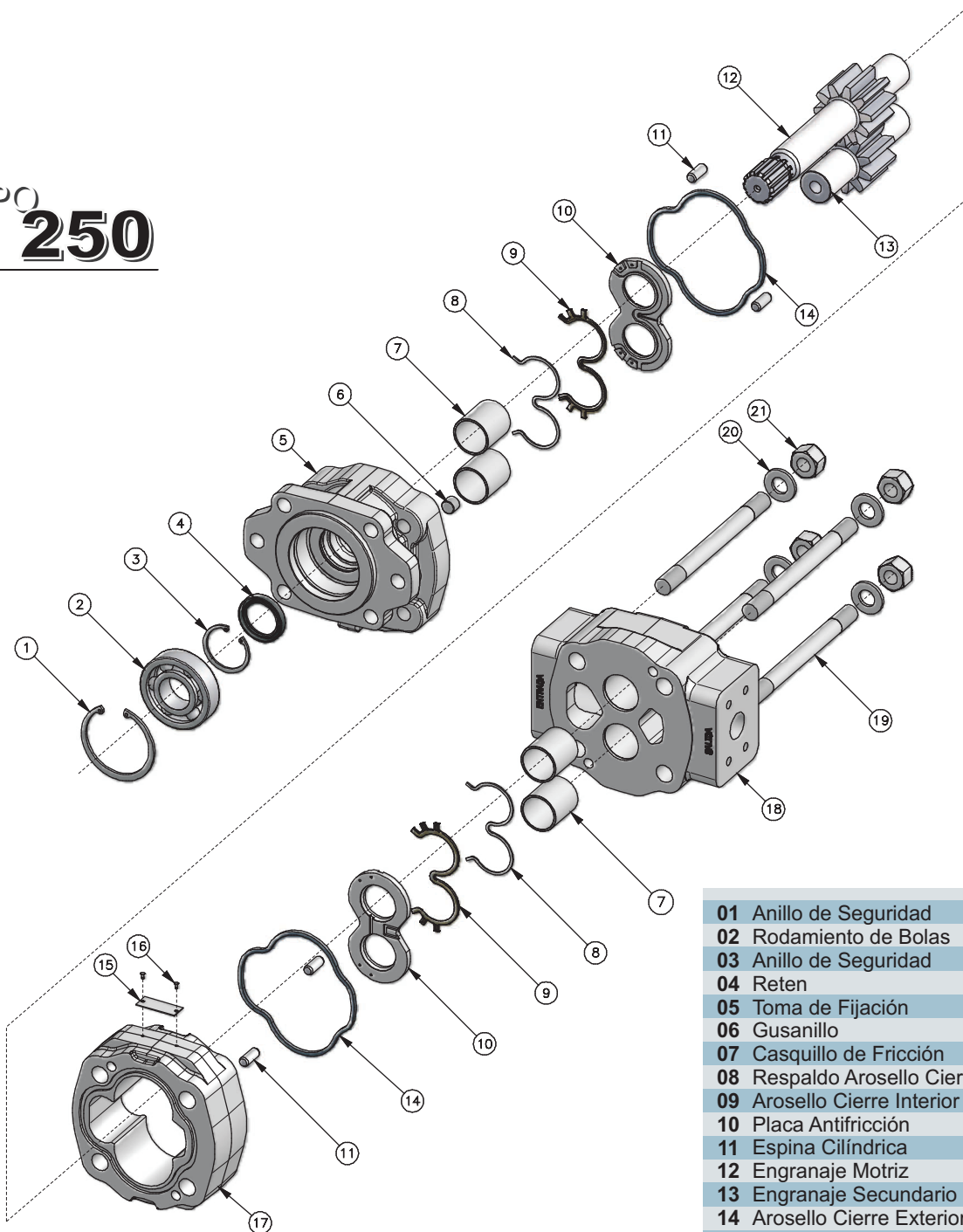

01	Anillo de Seguridad
02	Rodamiento de Bolas
03	Anillo de Seguridad
04	Reten
05	Toma de Fijación
06	Gusanillo
07	Casquillo de Fricción
08	Respaldo Arosello Cierre Interior
09	Arosello Cierre Interior
10	Placa Antifricción
11	Espina Cilíndrica
12	Engranaje Motriz
13	Engranaje Secundario
14	Arosello Cierre Exterior
15	Placa Identificación
16	Remache
17	Cuerpo
18	Tapa Posterior
19	Espárrago
20	Arandela Plana
21	Tuerca Hexagonal

LA EMPRESA SE RESERVA EL DERECHO DE REALIZAR MODIFICACIONES SIN PREVIO AVISO



BOMBA P250

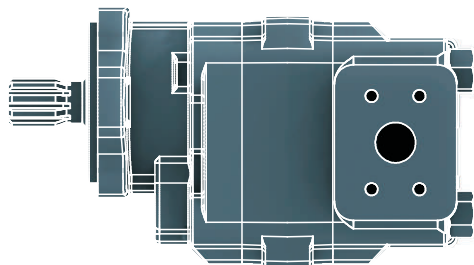

BOMBA TANDEM P250 / P250

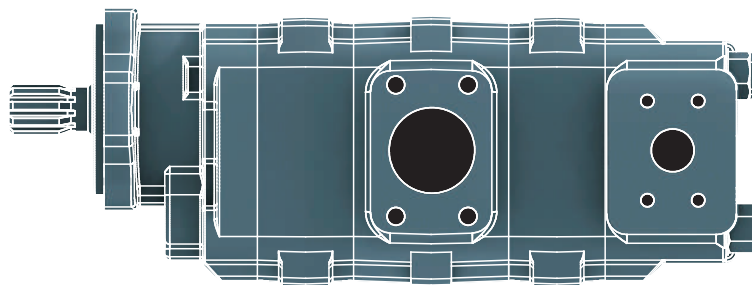

GRUPO
P 250

BOMBA TANDEM P250 / G15

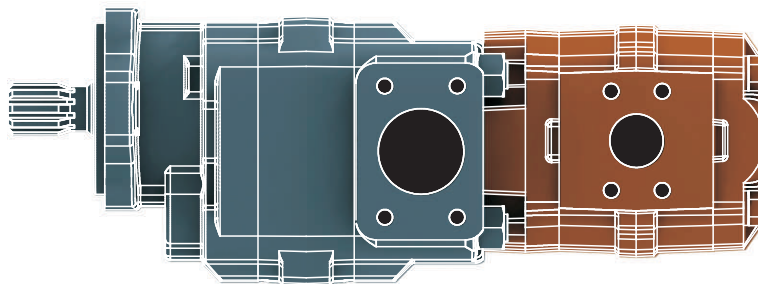

BOMBA TANDEM P250 / G1





TABLA DE VALORES

VALORACIONES		MODELOS									
		40	60	80	100	120	140	160	180	200	
ESPECIFICACIONES TÉCNICAS	Desplazamiento	cm ³ /rev	20.90	31.30	41.80	52.20	62.70	73.10	83.60	94	104.50
		in ³ /rev	1.28	1.91	2.55	3.19	3.83	4.46	5.10	5.74	6.38
	Caudal (a 2000 rpm)	lts/min	40	60	80	100	120	140	160	180	200
		gal/min	10.57	15.85	21.13	26.42	31.7	36.98	42.27	47.55	52.83
	Ancho de engranaje	mm	12.70	19.05	25.40	31.75	38.10	44.45	50.80	57.15	63.50
		inches	1/2"	3/4"	1"	1 1/4"	1 1/2"	1 3/4"	2"	2 1/4"	2 1/2"
	Ancho de cuerpo	mm	25.40	31.75	38.10	44.45	50.80	57.15	63.50	69.85	76.20
		inches	1"	1 1/4"	1 1/2"	1 3/4"	2"	2 1/4"	2 1/2"	2 3/4"	3"
	rpm	mínima	600								
		máxima	2400								
Máxima presión de operación	bar	250			230		210	190	175		
	psi	3625			3335		3045	2755	2538		
Máxima presión intermitente	bar	275		270		255	245	225	205	190	
	psi	3988		3915		3698	3553	3263	2973	2755	
Peso aproximado	kg	23.50	24.20	24.80	25.50	26.20	26.90	27.60	28.30	29.10	
	lb	51.80	53.35	54.67	56.22	57.76	59.30	60.85	62.39	64.15	

Temperatura durante el ensayo 50°C. Aceite hidráulico ISO 46.

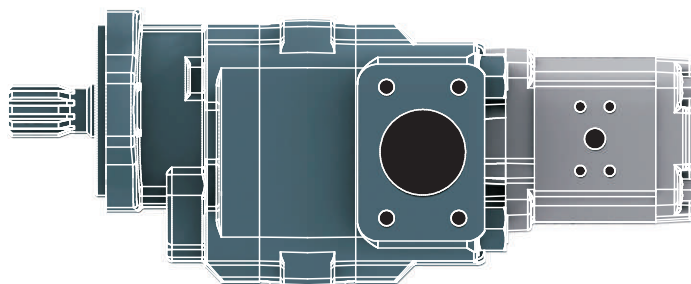
GRUPO P 250

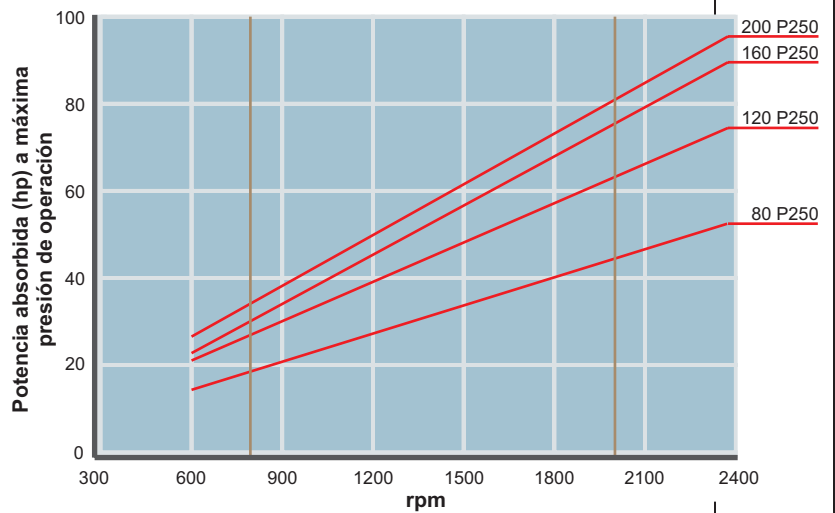
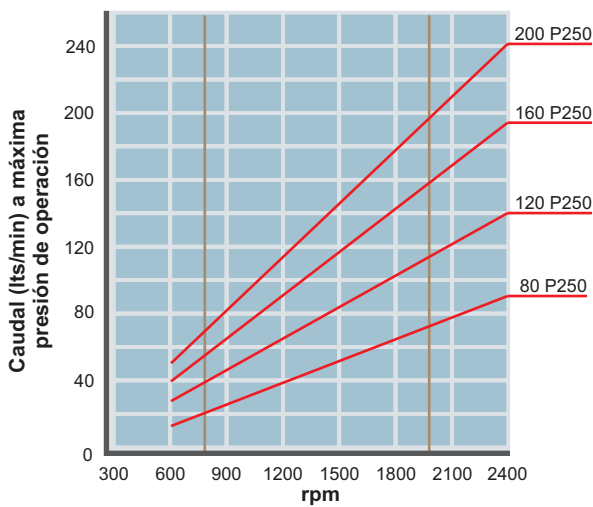

CUALQUIER OTRO REQUERIMIENTO TÉCNICO PODRÁ SER CONSULTADO A NUESTRO DEPARTAMENTO DE INGENIERÍA



RENDIMIENTO MOTOR P250

VELOCIDAD (rpm)	MODELOS											
	80			120			160			200		
	ENT.	SAL.		ENT.	SAL.		ENT.	SAL.		ENT.	SAL.	
	CAUDAL (Alimentación)	TORQUE	POTENCIA	CAUDAL (Alimentación)	TORQUE	POTENCIA	CAUDAL (Alimentación)	TORQUE	POTENCIA	CAUDAL (Alimentación)	TORQUE	POTENCIA
	lts/min gal/min	kgm In-lb	hp kW	lts/min gal/min	kgm In-lb	hp kW	lts/min gal/min	kgm In-lb	hp kW	lts/min gal/min	kgm In-lb	hp kW
800	39	9.5	10.6	58.6	14.4	16.1	78.1	19.6	21.9	96.8	24.8	27.7
	10.3	822.1	7.9	15.5	1247.6	12	20.6	1702.1	16.4	25.6	2151.9	20.8
1200	58.6	9.5	15.9	86.4	14.7	24.6	115.2	19.6	32.9	140.4	24.8	41.5
	15.5	822.1	11.9	22.8	1276.6	18.5	30.4	1702.1	24.6	37.1	2151.9	31.2
1600	76.8	10	22.4	115.20	15	33.6	152.3	20.1	44.8	188.8	25.1	56
	20.3	870.4	16.8	30.4	1305.6	25.2	40.2	1740.8	33.6	49.9	2176.0	42
2000	95.2	9.7	27.1	142.8	14.7	41.1	190.4	20.1	56	234.0	25.3	70.8
	25.1	841.4	20.3	37.7	1276.6	30.8	50.3	1740.8	42	61.8	2200.2	53.1
2400	114.2	9.6	32.1	171.4	14.5	48.7	228.5	19.8	66.5	280.8	24.2	81.2
	30.2	831.7	24.1	45.3	1262.1	36.5	60.4	1721.5	49.8	74.2	2103.5	60.9

Los ensayos se realizaron a una presión de operación de 175 bar
Temperatura durante el ensayo 50°C. Aceite hidráulico ISO 46.

GRUPO P 250

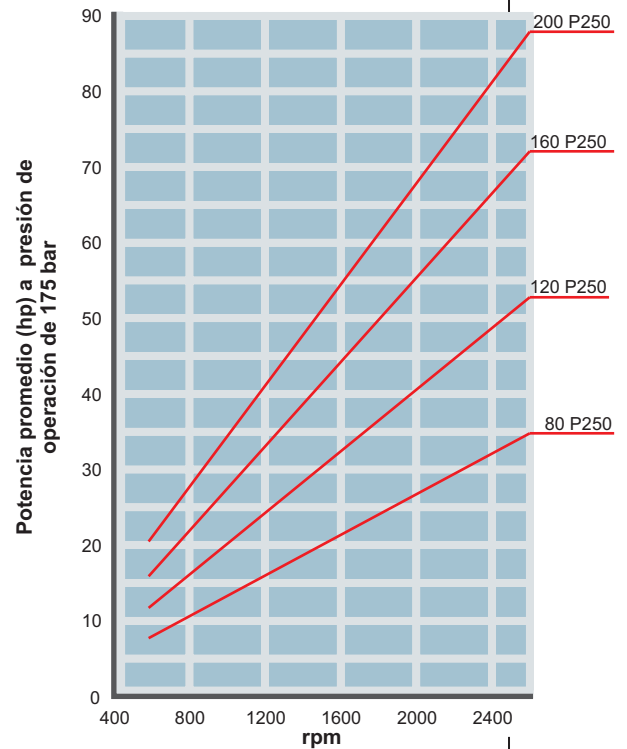
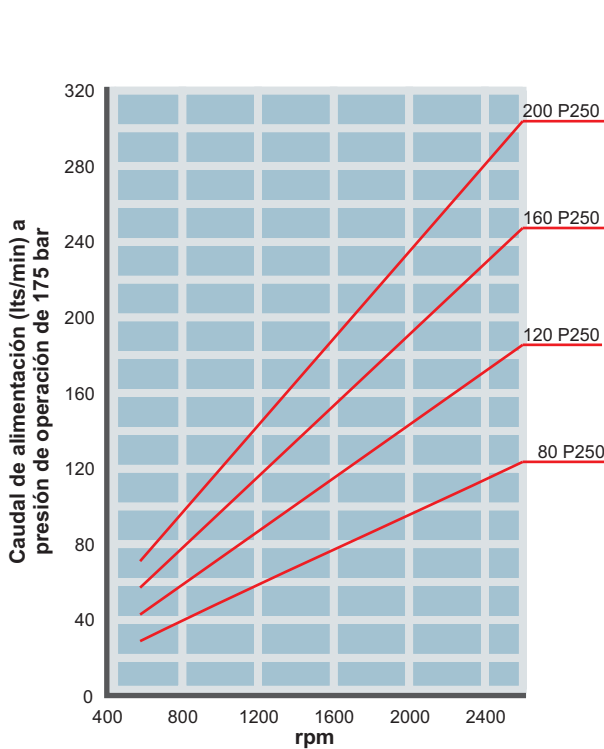

CUALQUIER OTRO REQUERIMIENTO TÉCNICO PODRÁ SER CONSULTADO A NUESTRO DEPARTAMENTO DE INGENIERÍA



TOMA DE FIJACIÓN CO-VK 4" (Ø101.6)

Corresponde a SAE B combinada 4 y 2 agujeros

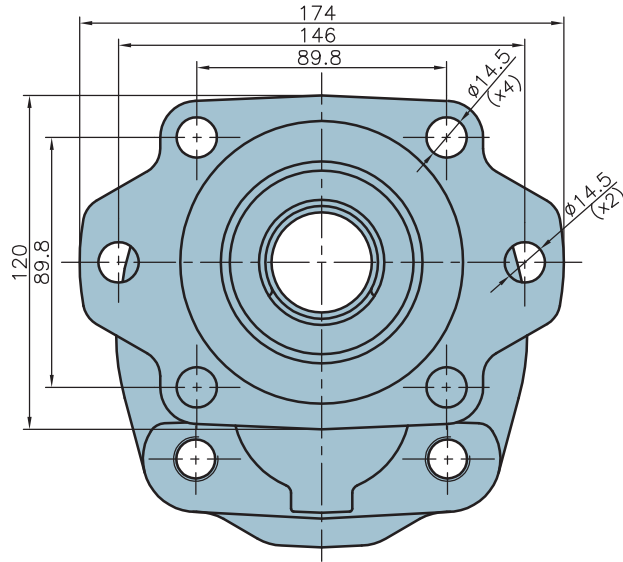
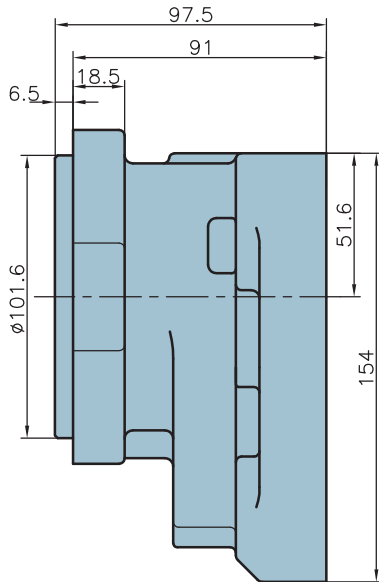

GRUPO
P 250

TOMA DE FIJACIÓN CO-VK 5" (Ø127)

Corresponde a SAE C combinada 4 y 2 agujeros

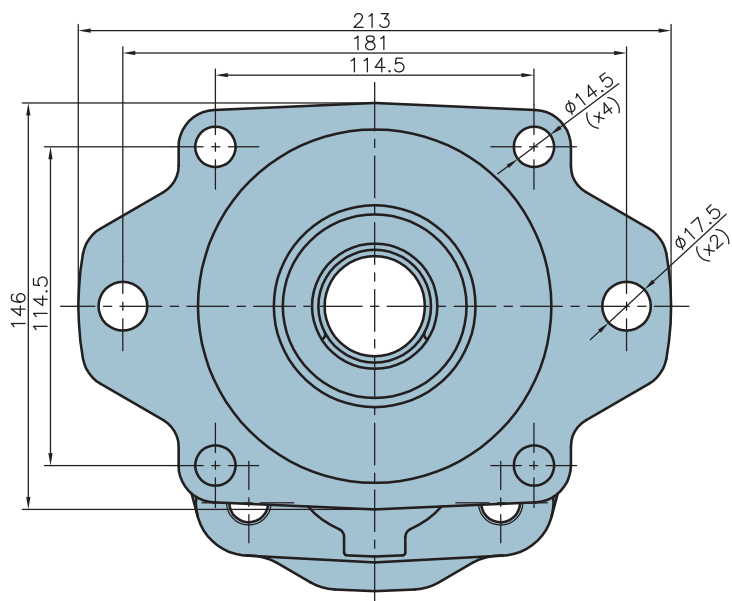
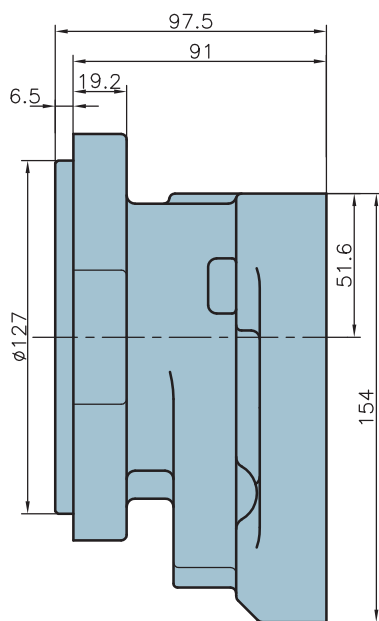

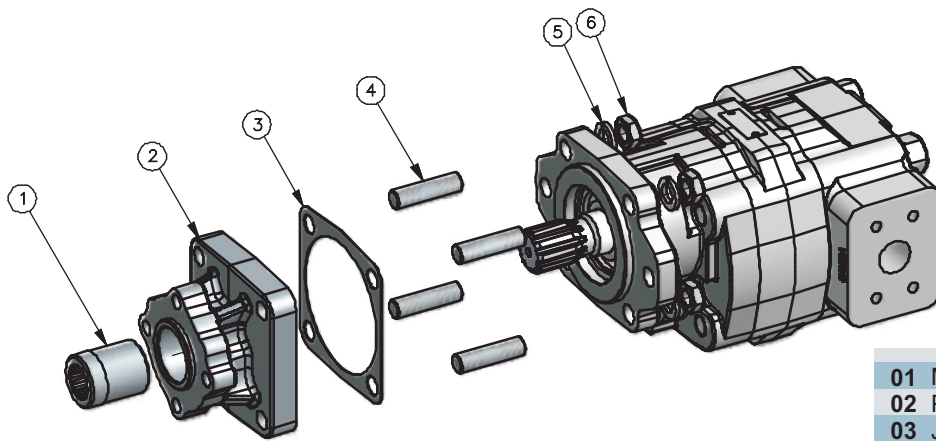

- 01 Manguito
- 02 Placa Adaptación TF
- 03 Junta
- 04 Espárrago
- 05 Arandela Grower
- 06 Tuerca Hexagonal

NOTA: Este sistema de adaptación "TF" se aplica sobre toma de fijación CO-VK 4", con eje Z=13 o Z=15 según norma SAE

PLACA ADAPTACIÓN "TF" (3 FIJACIONES)

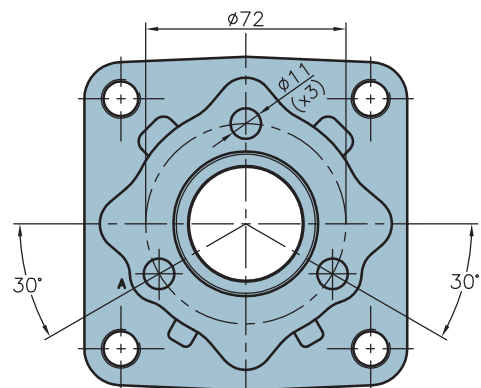
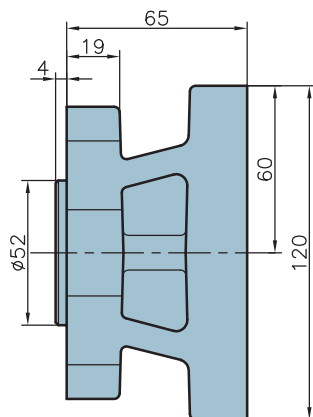

GRUPO
P 250

PLACA ADAPTACIÓN "TF" (4 FIJACIONES)

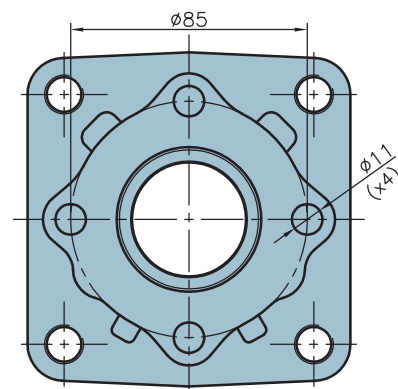
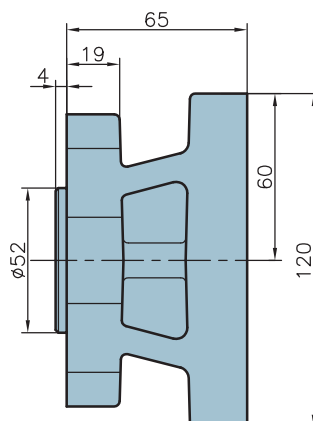



TOMA DE FIJACIÓN F82

Corresponde a SAE A

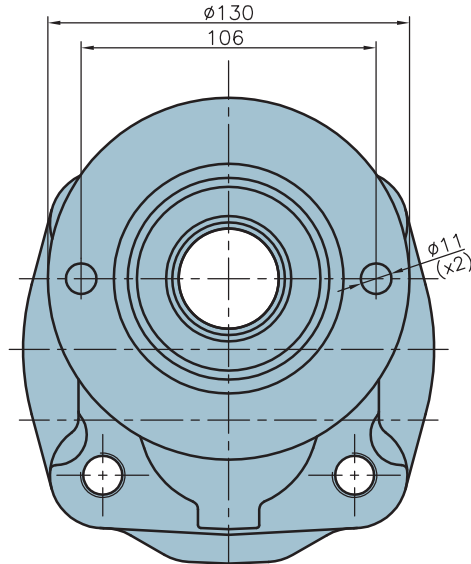
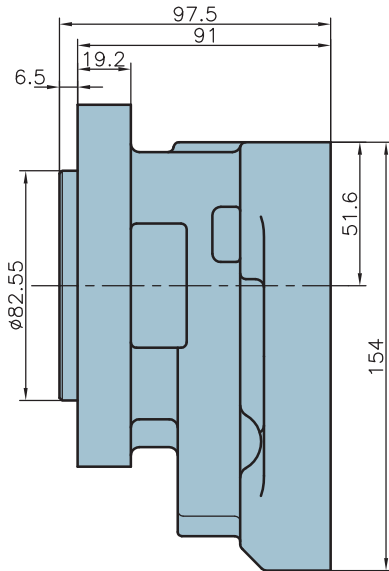

GRUPO P 250

TOMA DE FIJACIÓN PARA MAQUINARIA CHINA

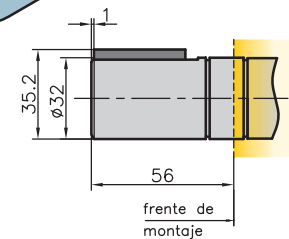
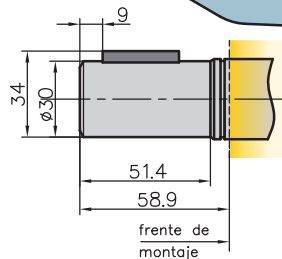
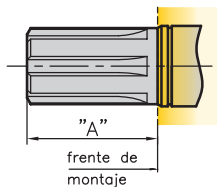
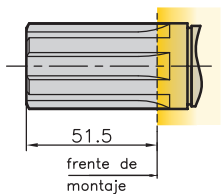
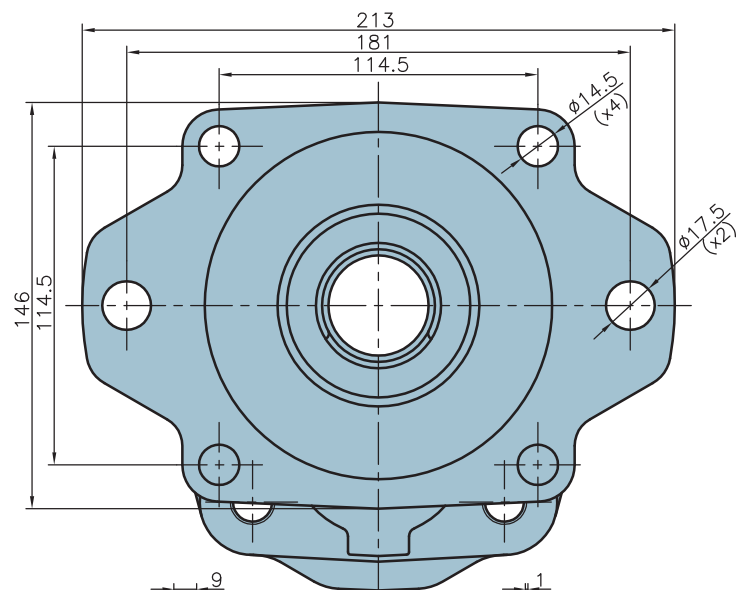
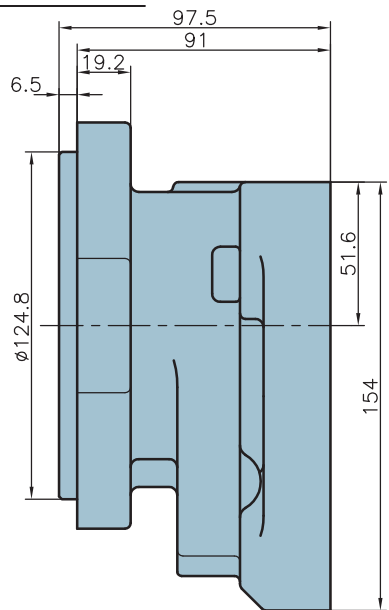

Z= 6 Estrias
 $\phi = 33.75$ mm

Z= 6 Estrias
 $\phi = 30$ mm

ANCHO DIENTE (mm)	COTA "A" (mm)
5.90	55.5
7.90	51.5

$\phi = 30$ mm
Chav. Cuadrada
8 x 8 x 30

$\phi = 32$ mm
Chav. Rectangular
10 x 8 x 36

NOTA: Para aplicaciones de maquinarias de origen chino, se puede combinar la toma de fijación con cualquiera de estos tipos de ejes.



ESTRIADO Z=13 (SAE)

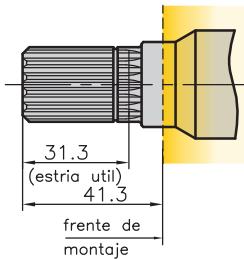

DP= 16/32
Ø= 22.22 mm (7/8")

CILÍNDRICO Ø22.2 (7/8") (SAE)

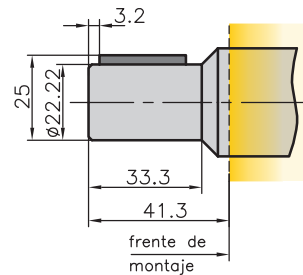

Ø= 22.22 mm (7/8")
Chav. Cuadrada
1/4" x 1/4" x 1"

ESTRIADO Z=14 (SAE)

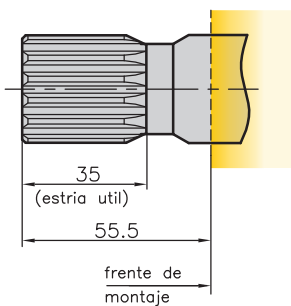

DP= 12/24
Ø= 31.75 mm (1 1/4")

CILÍNDRICO Ø31.75 (1 1/4") (SAE)

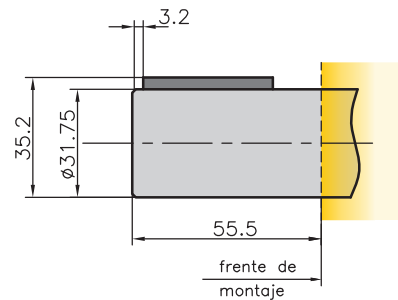

Ø= 31.75 mm (1 1/4")
Chav. Cuadrada
5/16" x 5/16" x 1 1/2"

GRUPO
P 250

ESTRIADO Z=15 (SAE)

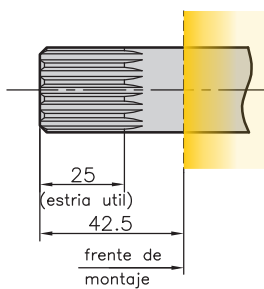

DP= 16/32
Ø= 25.4 mm (1")

ESTRIADO Z=17

Aplicación Pala y retro CASE 580L

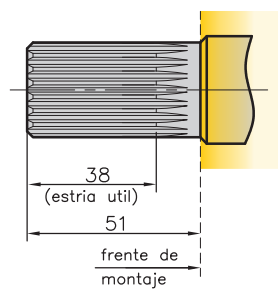

DP= 16/32
Ø= 28 mm

CILÍNDRICO Ø25.4 (1")

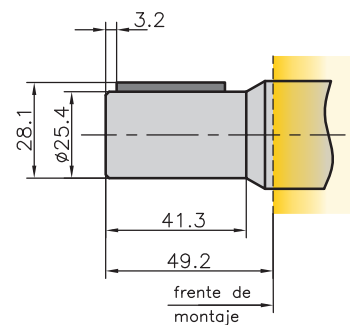

Ø= 25.4 mm (1")
Chav. Cuadrada
1/4" x 1/4" x 1 1/4"



CUERPO UNIDIRECCIONAL

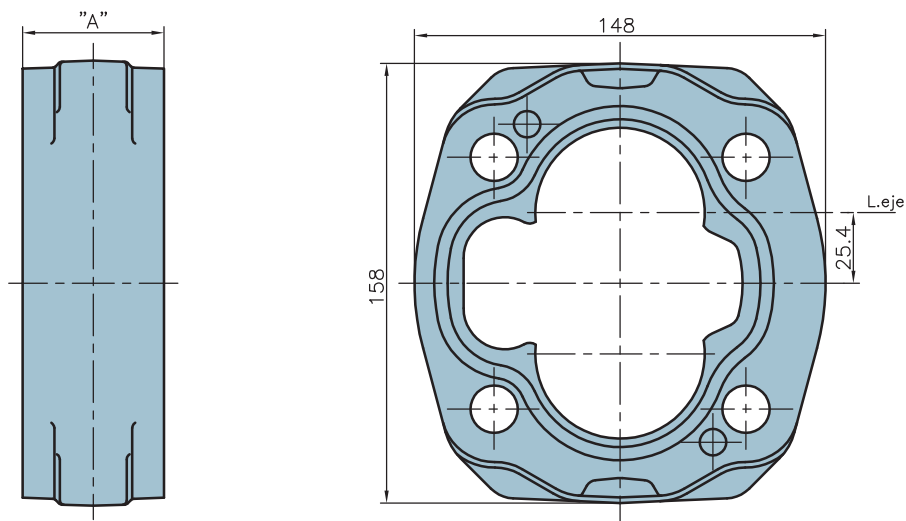

GRUPO
P 250

MODELO	COTA "A" (mm)
40-P250	25.40
60-P250	31.75
80-P250	38.10
100-P250	44.45
120-P250	50.80
140-P250	57.15
160-P250	63.50
180-P250	69.85
200-P250	76.20

PLACA ANTIFRICCIÓN

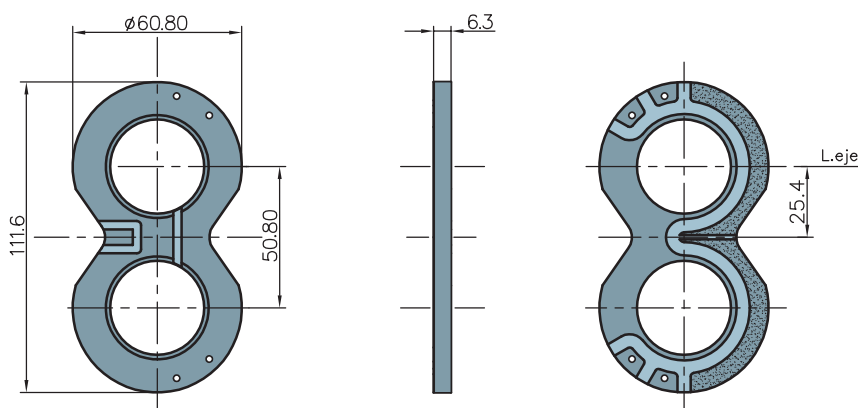



TAPA POSTERIOR CON ENTRADA Y SALIDA LATERAL

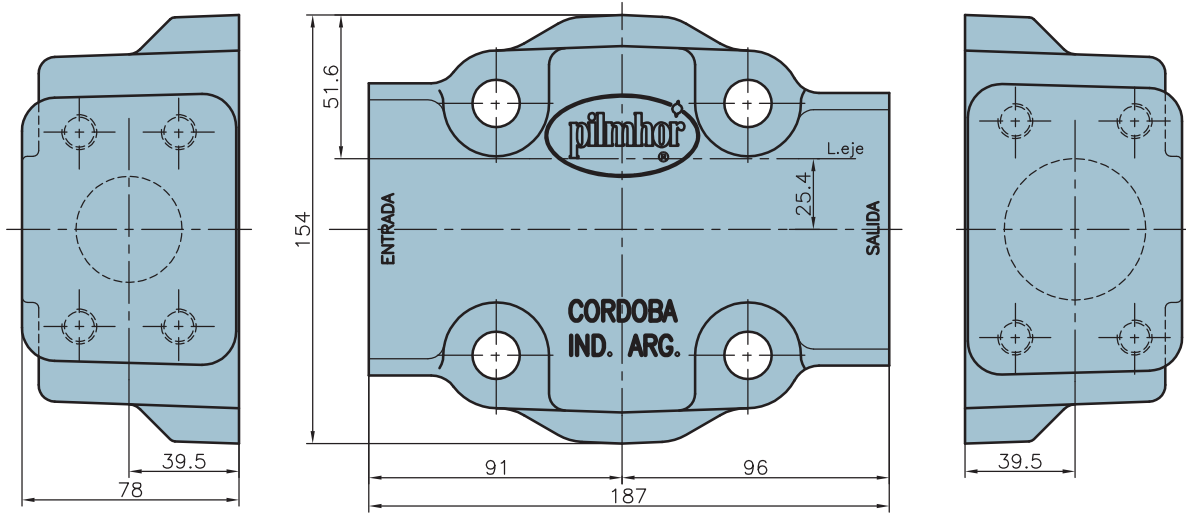

Armado normal

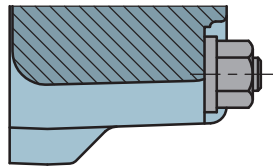

Armado con prolongación de espárragos (c/u 2)

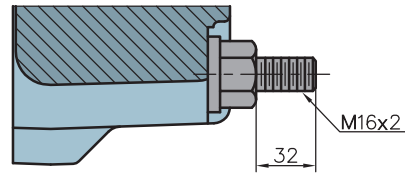

GRUPO
P 250

TAPA POSTERIOR CON ENTRADA Y SALIDA POSTERIOR

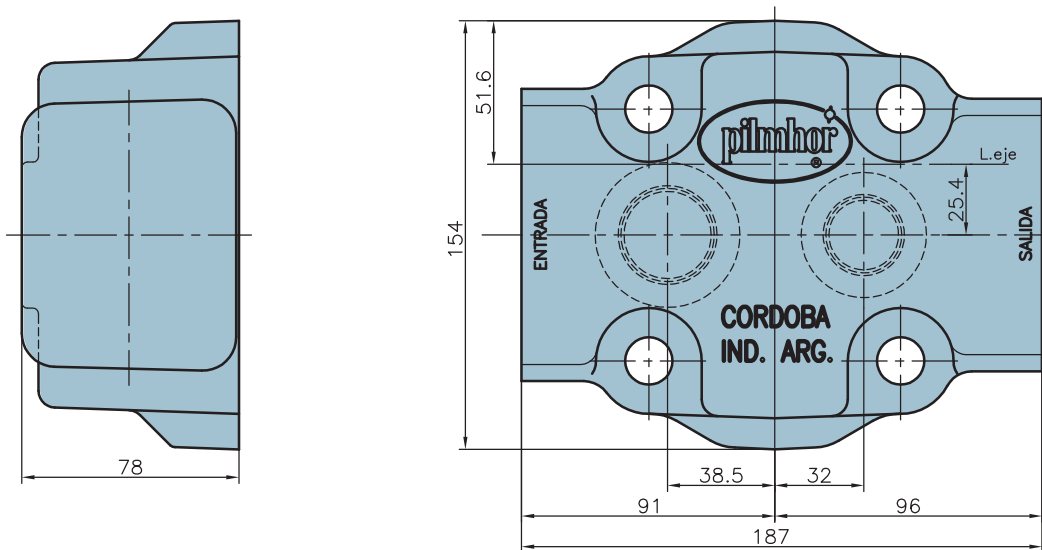

NOTA: Es posible la combinación de entrada lateral con salida posterior, como así también, salida posterior únicamente (con entrada en el intermediario tandem).



TANDEM P250 / P250

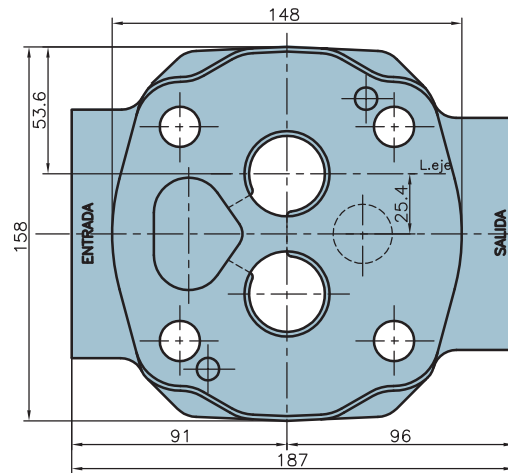
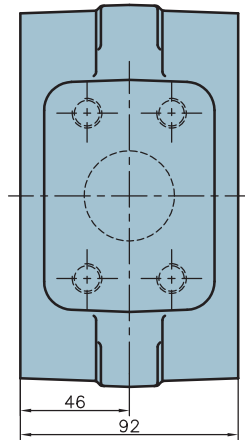

TANDEM P250 / G15

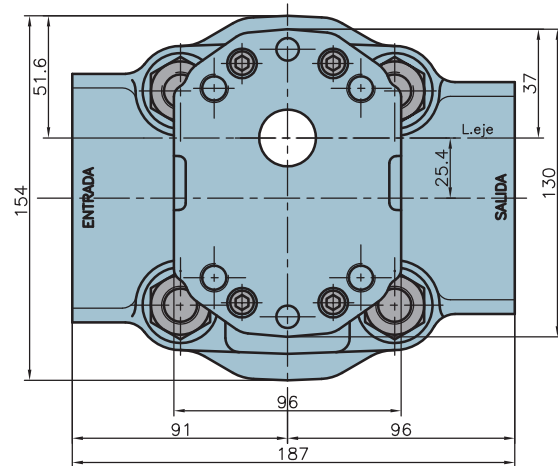
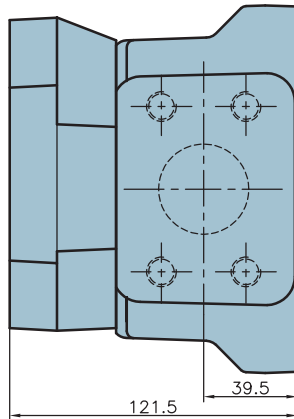

TANDEM P250 / G1

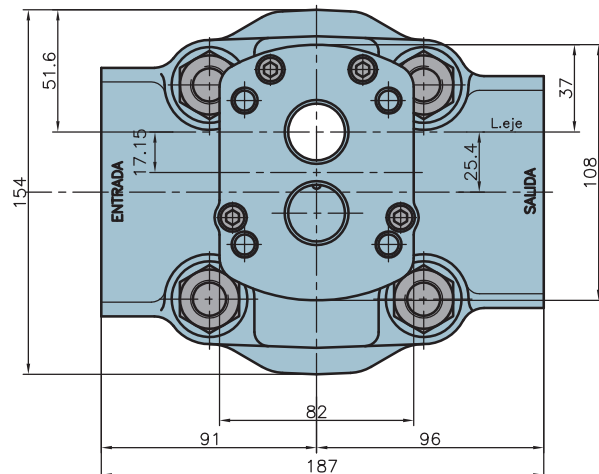
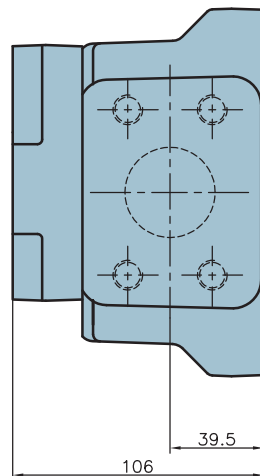

GRUPO
P 250

NOTA: es posible armar una bomba tandem P-250/G1, con una única entrada de alimentación, respetando como máximo un caudal real de 40 lts/min en la bomba trasera (G1).



PERFORADO SAE STANDARD

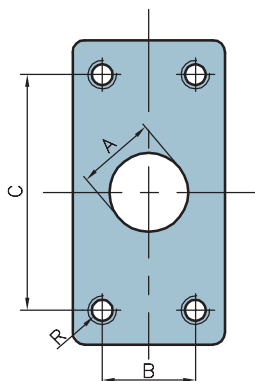

CÓDIGO DEL PERFORADO (F)

NOMINAL (OD TUBE)	A (mm)	B (mm)	C (mm)	R (mm)	CÓDIGO Nº (SAE)	TAPA POSTERIOR E/S LATERAL		INTERMEDIARIO TANDEM	
						ENT.	SAL.	ENT.	SAL.
1/2"	12.70	17.47	38.10	5/6" UNCx18	8	•	•	•	•
3/4"	19.05	22.22	47.62	3/8" UNCx16	12	•	•	•	•
1"	25.40	26.18	52.37	3/8" UNCx16	16	•	•	•	•
(*1 1/4"	31.75	30.17	58.72	7/16" UNCx14	(* 20	•	•	•	•
1 1/2"	38.10	35.71	69.85	1/2" UNCx13	24	•	•	•	•
2"	50.80	42.87	77.77	1/2" UNCx13	32	•	-	•	-

EJEMPLO: PERFORADO SAE STANDARD "F20" CORRESPONDE A NOMINAL (*) 1 1/4", DEBIENDOSE ACLARAR SI PERTENECE A ENTRADA O SALIDA.

PERFORADO CON ROSCA CÓNICA

GRUPO P 250

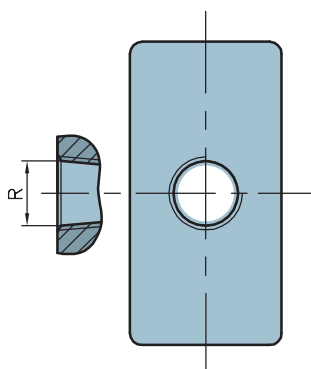

CÓDIGO DEL PERFORADO (P)

NOMINAL (OD TUBE)	ROSCA R	CÓDIGO Nº (SAE)	TAPA POSTERIOR E/S LATERAL		TAPA POSTERIOR E/S POSTERIOR		INTERMEDIARIO TANDEM	
			ENT.	SAL.	ENT.	SAL.	ENT.	SAL.
1/2"	1/2" NPTx14	8	•	•	•	•	•	•
3/4"	3/4" NPTx14	12	•	•	•	•	•	•
1"	1" NPTx11 1/2	16	•	•	•	•	•	•
(*1 1/4"	1 1/4" NPTx11 1/2	(* 20	•	•	•	-	•	•
1 1/2"	1 1/2" NPTx11 1/2	24	•	-	-	-	•	-

EJEMPLO: PERFORADO C/ROSCA CONICA "P20" CORRESPONDE A NOMINAL (*) 1 1/4", DEBIENDOSE ACLARAR SI PERTENECE A ENTRADA O SALIDA.

PERFORADO CON ROSCA CILÍNDRICA PARA AROSELLO

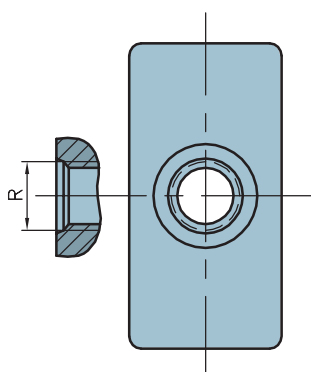

CÓDIGO DEL PERFORADO (S)

NOMINAL (OD TUBE)	ROSCA R	CÓDIGO Nº (SAE)	TAPA POSTERIOR E/S LATERAL		TAPA POSTERIOR E/S POSTERIOR		INTERMEDIARIO TANDEM	
			ENT.	SAL.	ENT.	SAL.	ENT.	SAL.
1/2"	3/4" UNFx16	8	•	•	•	•	•	•
5/8"	7/8" UNFx14	10	•	•	•	•	•	•
3/4"	1 1/16" UNFx12	12	•	•	•	•	•	•
7/8"	1 3/16" UNFx12	14	•	•	•	•	•	•
1"	1 5/16" UNFx12	16	•	•	•	-	•	•
1 1/4"	1 5/8" UNFx12	20	•	•	-	-	•	•
(*1 1/2"	1 7/8" UNFx12	(* 24	•	-	-	-	•	•
2"	2 1/2" UNFx12	32	-	-	-	-	•	-

EJEMPLO: PERFORADO C/ROSCA CILINDRICA "S24" CORRESPONDE A NOMINAL (*) 1 1/2", DEBIENDOSE ACLARAR SI PERTENECE A ENTRADA O SALIDA.



BRIDAS ROSCADAS

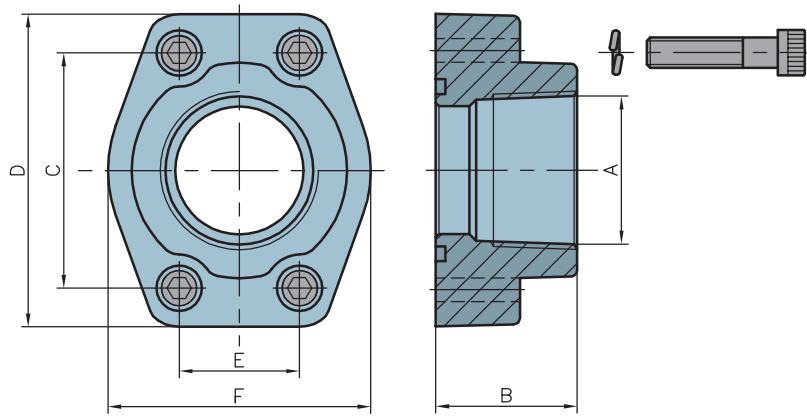

MEDIDA SAE	DIMENSIONES					
	ROSCA (A)	B	C	D	E	F
3/4"	3/4" NPTx14	35	47.62	65	22.22	44
1"	1" NPTx11 1/2	35	52.37	70	26.18	51
1 1/4"	1 1/4" NPTx11 1/2	40	58.72	79	30.17	63
1 1/2"	1 1/2" NPTx11 1/2	45	69.85	93	35.71	72
2"	2" NPTx11 1/2	45	77.77	102	42.87	90

GRUPO
P 250

MEDIAS BRIDAS

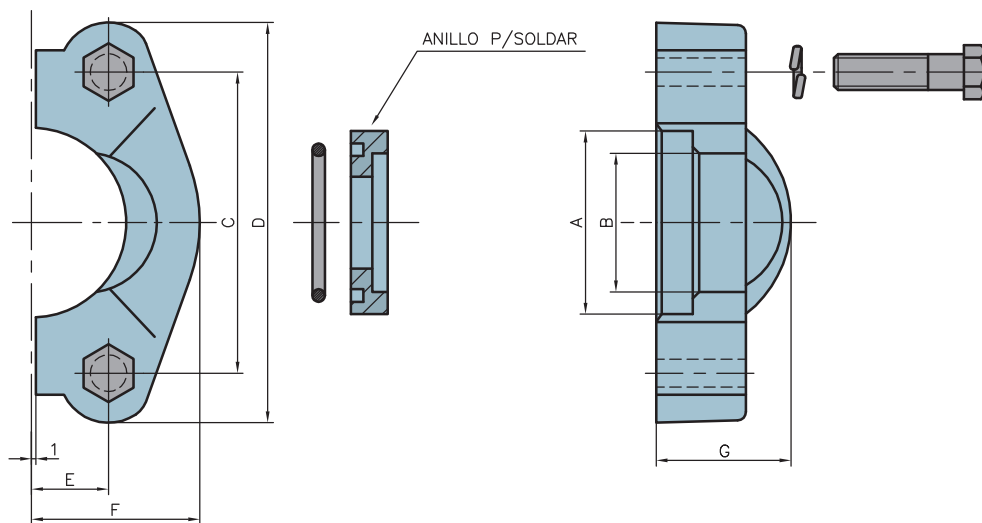

MEDIDA SAE	DIMENSIONES						
	A	B	C	D	E	F	G
2"	72.24	62.74	77.77	102	21.44	48.20	26



1

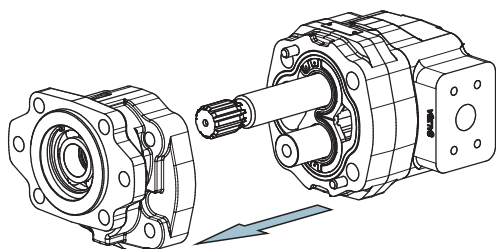

2

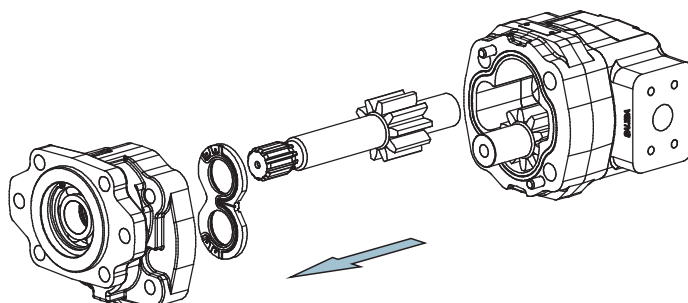

3

GRUPO
P 250

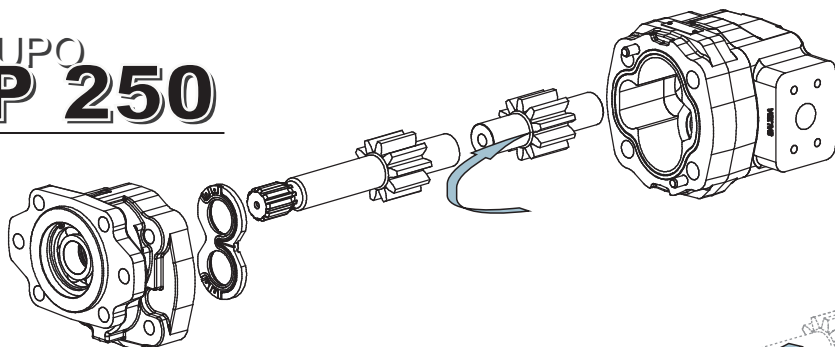

4

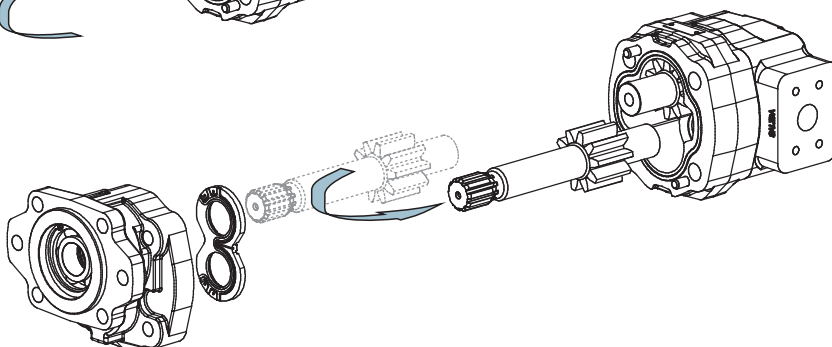

5

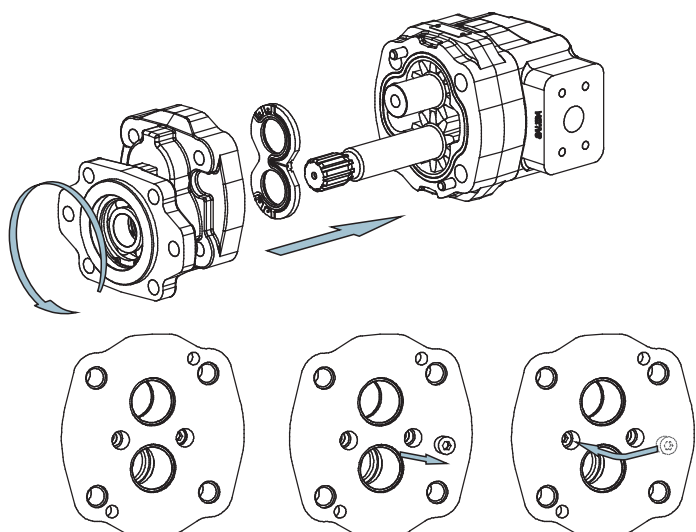

6

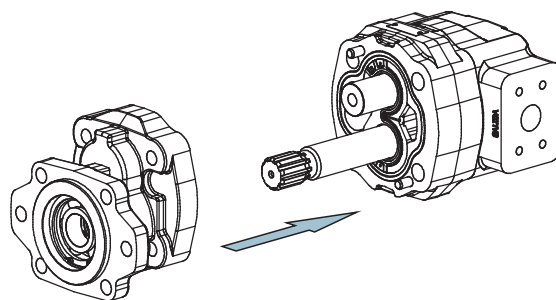

Modificar la posición del gusanillo, en función del giro.